

A parametric numerical study on the horizontal load-bearing capacity of the FPB-sheated timber framed wall elements with openings

E. Kozem Šilih^{1,*}, M. Premrov¹, M. Kuhta¹, S. Šilih¹

Received: October 2013, Revised: February 2014, Accepted: November 2014

Abstract

The paper presents a parametric numerical study on the horizontal load-bearing capacity of timber framed wall elements coated with single fibre plaster boards (FPB) that can be used in the construction of single- or multi-storey prefabricated buildings. The research deals with both the full elements (without any opening) and with elements containing an opening. The key behaviour indicators like the racking stiffness and strength were determined and presented as ratios dependent on the opening area. A comparative study has proved that none of the methods from the literature that were previously developed for different types of wall elements can be accurately applied to the FPB-sheated panels. It has also been shown that the methods currently available in the European design codes underestimate the capacity of wall elements with openings. Based on the results some diagrams are proposed that enable quick and efficient determination of the essential properties of wall elements with arbitrary areas of openings and may thus represent a useful tool for the structural design process.

Keywords: Timber structures, Timber-frame wall elements, Fibre-plaster boards, Numerical analysis, Parametric numerical study, Opening coefficient.

1. Introduction

Recently, lightweight prefabricated structures are becoming more and more popular in many areas around the world. One of the increasingly common used systems for both single- and multi-storey buildings are the prefabricated timber structures with timber-framed wall elements as the main vertical load-bearing members. The wall elements are composed from a timber frame, which in general resists the vertical loads only, and the sheathing boards, which provide the horizontal stability and should be able to resist the horizontal (wind and earthquake) loads. Using adequate shear connection between the timber frame and the boards, the wall elements may be considered as composite systems. The sheathing boards are usually made of either a wood-based or the fiber plaster material, where the latter is often preferred due to its good thermal and sound insulation properties as well as high fire resistance. Due to the brittle behaviour and the relatively low tensile resistance of the fiber plaster boards (FPB), the latter represent the weak component of the composite system.

In conventional buildings (i.e. residential, office, etc.) many walls may have several openings for functional reasons, doors and windows.

The openings reduce the stiffness and the load-bearing capacity of the structure, while additional damage is expected to occur due to stress concentrations at the corners of the openings. The main subject of the present paper is the influence of the opening on the horizontal strength and stiffness of the FPB-sheated timber-frame wall elements.

Several research papers have been published in the past discussing the influence of the openings on the load-bearing capacity of different structures, e.g. reinforced concrete shear walls [1], timber composite beams [2], masonry structures [3] and also plywood-sheated timber-frame wall elements [4]-[6]. Prior to this research an extensive experimental study of the timber framed wall elements without openings with different types of sheathing boards and different types of reinforcement was carried out [7 - 9]. Based on the experimental tests an analytical procedure was also proposed [10, 11] which proved to yield good results for the estimation of the horizontal stiffness and load-bearing capacity of the wall panels. As in the analytical procedure the wall panels are treated as cantilever beams having a uniform composite cross-section, the proposed equations are applicable to the wall elements without any openings (referred to hereafter as »full wall elements«) only. As already mentioned, the influence of the openings on the strength and stiffness of the structure may be significant. Currently, the European design code for timber structures, Eurocode 5 [12] proposes two alternative methods for the wall elements with openings. By the first method (Method A) the wall

* Corresponding author: erika.kozem@um.si
1 Assistant Professor, University of Maribor, Faculty of Civil Engineering, Smetanova ul.17, SI-2000 Maribor, Slovenia

elements with openings are ignored and the entire horizontal load should be transferred by the full elements only. By the second method (Method B), the horizontal capacity of the elements with openings is partly accounted for in a way, that the parts of an element on both sides of the opening are considered as separate full elements. However, as according to Eurocode 5 the Method B should only be used for wall elements with wood-based sheathing boards, only Method A can be applied to the FPB-coated timber framed wall elements.

Different experimental studies performed on timber-framed wall elements with openings coated with plywood boards [6] and single FPB [13, 14] have shown, however, that the racking capacity as well as the stiffness of wall elements with openings is in reality higher than assumed by the mentioned methods from EC5. Moreover, a numerical analysis on the timber-framed wall elements coated with single FPB [15] has shown, that the wall elements with openings may have a considerable impact on the load-bearing capacity of wall systems subjected to horizontal loads. By overtaking a part of the load these elements improve the structure's elastic resistance, while they also provide additional ductility in the post-elastic phase. In the numerical study the wall elements were modelled by considering the nonlinear (brittle) behaviour of the sheathing boards as well as the nonlinear elasto-plastic behaviour of the shear connectors. The results proved good coincidence with the results of the experimental tests regarding the initial stiffness of the structure, the value of the force at which the first irreversible damage (i.e. crack in the sheathing boards) occurred, as well as the post-elastic behaviour until the ultimate capacity was reached. Due to the computational expense, however, the developed numerical models are not very suitable for the analysis of larger structural systems in every-day engineering practice. For the purpose of an efficient structural design it is important to have procedures available, that enable simple but sufficiently accurate calculation of the essential properties of structural elements. One example of such an approach is based on the so-called »opening coefficient«, introduced in [5, 6]. The opening coefficient is calculated depending on the geometry and the area of the opening in the wall element. In addition, the mechanical properties of the wall element (strength, stiffness) are represented in the form of ratios normalised to the properties of a corresponding full element. In this way, the so-called strength and stiffness ratios are obtained and can be represented as functions of the opening coefficient. As a result, relatively simple diagrams and expressions for the estimation of the racking capacity of wall elements with openings were presented. While the reference [6] deals with plywood-coated timber-framed wall elements, a similar approach was also used in [16] for the case of solid cross-laminated wooden KLH panels with openings.

In the present paper the timber-framed wall panels with openings coated with single FPB are discussed. A

parametric numerical analysis of the wall panels with different sizes of openings for doors/windows is presented. The comparison of the results obtained for different types of wall panels from literature has proven that the FPB coated panels are specific due to the above mentioned fact that their behaviour is mainly dependent on the relatively low tensile resistance and the consequent occurrence of cracks in the sheathing boards. For this reason they require special consideration also in the structural design codes. Based on the results, some diagrams and expressions are derived that enable quick and efficient evaluation of the horizontal load-bearing capacity and stiffness of the analysed wall panels. In this way, they may represent a useful tool for the design of prefabricated wall systems in the everyday engineering practice.

2. Parametric Numerical Study

2.1. Description of wall panel specimens

The numerical analysis is based on the experimental research previously performed on the timber-framed wall elements coated with single fibre plaster boards. Regarding the geometry, three groups of different wall elements were tested, see also [9] and [13]:

- The full wall element (without opening) – labeled as element G2.
- The wall element with a larger opening – labeled as element O1.
- The wall element with a smaller opening – labeled as element O2.

The geometry of the wall elements is shown in Figs. 1 and 2. The elements are composed of a timber frame and are coated on both sides by a single fibre plaster board of thickness $t = 1,5$ cm. The cross-sectional dimensions of the elements of the timber frame amount to 8/9 cm (the lower and upper beam), 9/9 cm (the side vertical beams) and 4,4/9 cm (all internal beams). The sheathing boards were connected to the timber frame by steel staples. The general intermediate distance between the staples amounted to 7,5 cm, with the exception of the intermediate beam in element G2 and the intermediate beams below the openings in elements O1 and O2 where the distance between the staples was 15 cm. The details regarding the timber in fiber-plaster materials used are given in Table 1. As the mechanical fasteners between the timber frame and the plaster boards, the staples of diameter $\Phi = 1,53$ mm (made of steel with the tensile resistance of 900 N/mm²) were used.

Table 1 The considered material properties (values is N/mm²)

Timber (C22) [19]				Fibre-plaster boards [20]			
$E_{0,mean}$	$f_{t,0,k}$	$f_{c,0,k}$	$f_{m,k}$	E_b	G_b	f_{bt}	f_{bc}
10000	13	20	22	3000	1200	2,5	20

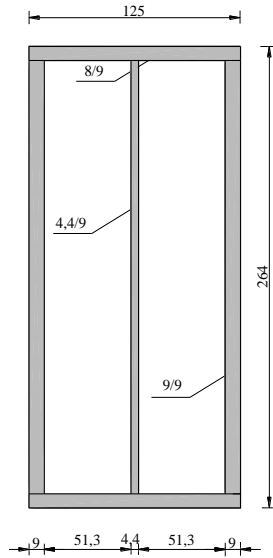

Fig. 1 The geometry of the element G2; (all dimensions in cm)

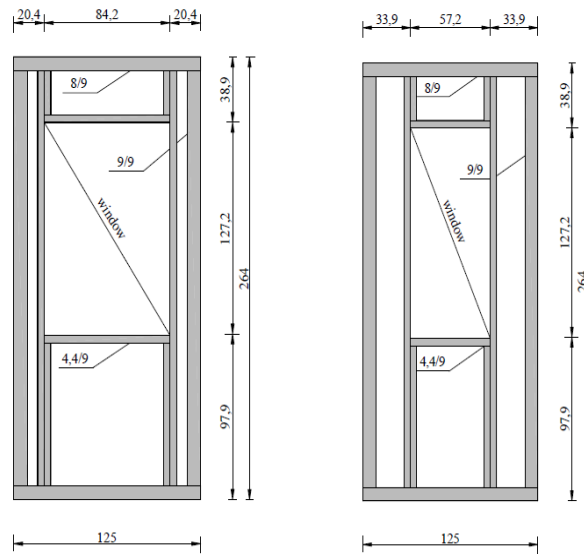

Fig. 2 The geometry of the elements O1 (left) and O2 (right); (all dimensions in cm)

For a detailed comparative analysis the numerical analysis was also performed on two additional types of timber-frame wall elements, namely the wall element with a small opening (labeled as element OM) and the wall

element with the largest (door) opening (labeled as element OV). The geometry of the additional wall elements is shown in Fig. 3.

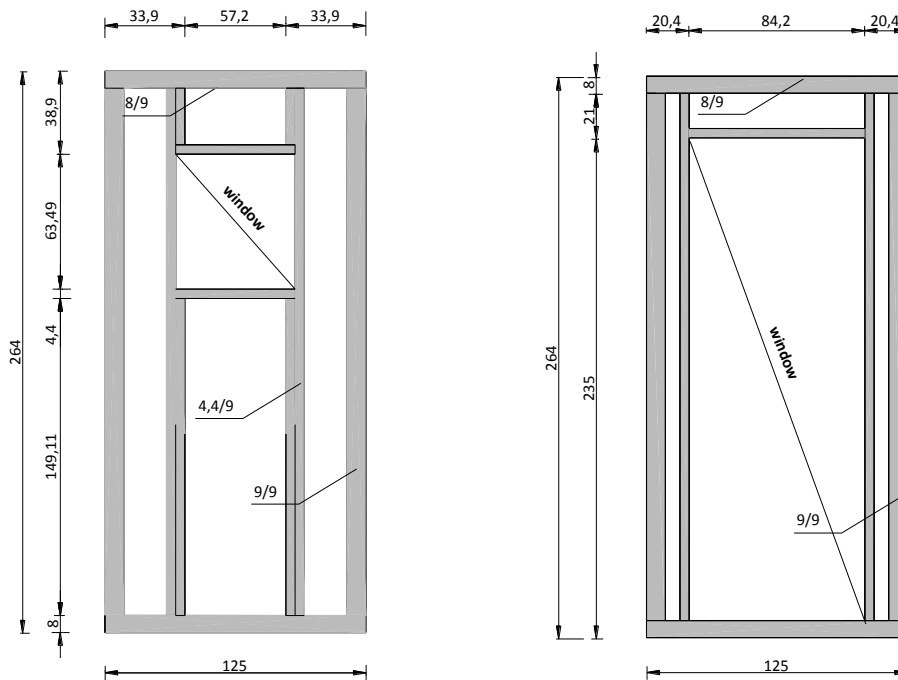

Fig. 3 The geometry of the elements OM (left) and OV (right); (all dimensions in cm)

2.2. Mathematical modelling

A detailed description of the numerical models and the process of the numerical analyses was presented in [15]. The studied structures have been modelled and analysed using the commercial FEM computer software SAP2000 Nonlinear v 14.0.0 [17]. The behaviour of the analysed wall elements is largely tied to the properties of the plaster

material, i.e. its low tensile resistance, and the consequent occurrence of cracks. The plaster material was therefore modelled as acting linearly elastic in compression, while in tension a nonlinear material model simulating the brittle cracking behaviour was used. The sheathing boards were modelled using the nonlinear shell elements offered by the SAP2000 software. The timber material was considered as an isotropic elastic material (with the modulus of elasticity

$E_{0,mean}$) and the elements of the timber frame were modelled as the simple plane-stress elements. The mechanical fasteners between the timber frame and the sheathing boards, i.e. the staples, were modelled according to the three-linear diagram for the slip modulus K , presented in [15]. The staples were modelled using the nonlinear link elements (springs) with a multi-linear elasto-plastic force-displacement relation, presented in [15].

The general static model of the studied wall-panel

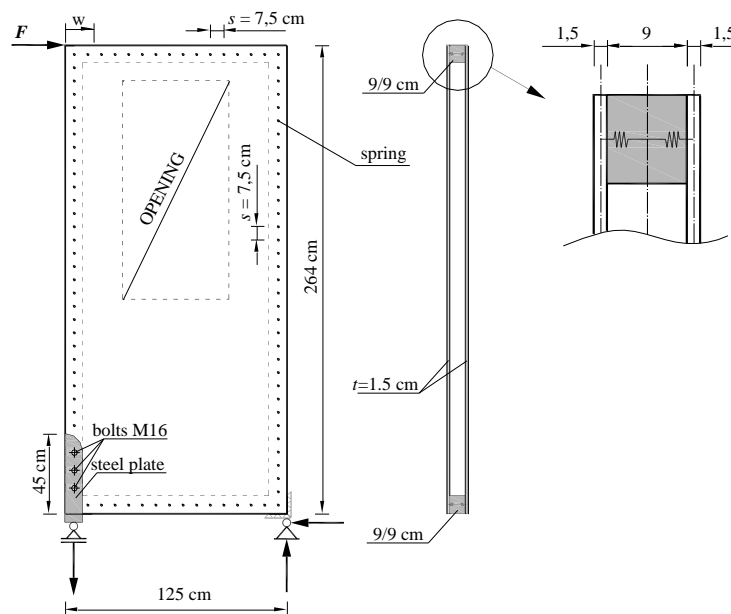

Fig. 4 The static model and the general geometry for the numerical model of the wall element (left: elevation, right: cross section)

During the experimental tests the force (F) was increased, while the displacement (w) at the top of the cantilever was measured, see Fig. 4. A detailed description of the experimental tests can be found in [13-14]. In order to simulate the experimental tests as accurate as possible, the numerical analysis was carried out in two successive stages. In the first stage the structure was subjected to the self weight only. The calculated stress state was considered as the initial state for the subsequent second stage. The second stage was carried out as a multi-step nonlinear analysis with the force (F) increasing from zero by the step of 0.1 kN until the ultimate capacity of the structure was reached. As the ultimate capacity was adopted the value of the force (in the following denoted by F_u) at the last calculated step, after which no subsequent solution was found by the SAP2000 solver in 50 subsequent steps. In addition to the previously discussed material nonlinearities, the geometric nonlinearities (the $P-\Delta$ effects) were also accounted for in both analysis stages.

2.3. Results of the numerical analyses

Fig. 5 shows the progress of the displacements (w) with regard to the increasing horizontal force (F), i.e. the $F-w$ diagrams obtained by the numerical analyses of the different wall-element specimens, described in the previous sections.

structure is presented in Fig. 4. It should be noted that the supporting conditions shown represent the setup for the experimental tests [13]. The relatively stiff tensile supports (using steel plates and bolts) were applied in order to eliminate the impact of the supporting on the behaviour of the wall panel as much as possible. In the numerical models, the bolts of the tensile support were considered as spring supports, while the compressive support was modelled using rigid point supports.

In Table 2 the numerical values of the key behaviour indicators are presented. F_{cr} stands for the value of the horizontal force at which the first irreversible nonlinear deformations appeared (i.e. cracks in the sheathing boards), while F_u (also indicated in Fig. 5) represent the value of the force at which the collapse occurred (i.e. the ultimate capacity). Besides, two additional quantities regarding the stiffness of the wall panels are also given, namely:

- the initial stiffness K_i , defined as the ratio between F_{cr} and the corresponding displacement w_{cr} at the formation of the first crack; K_i thus corresponds to the average stiffness in the range of the elastic behavior (i.e. the region of reversible deformations);
- the so-called racking stiffness R , as defined in the European standard for the racking tests of timber-framed wall panels, EN 594 [18]; R represents the average stiffness of the structure in the range of 20% to 40% of the ultimate capacity.

$$R = \frac{F_4 - F_2}{w_4 - w_2},$$

where

F_2 is the racking load of $0,2 F_{max}$ in Newtons, F_4 is the racking load of $0,4 F_{max}$ in Newtons, w_2 and w_4 is the deformation in millimetres.

As in conventional multilevel buildings subjected to horizontal loads the floor slabs act as rigid diaphragms, the loads are distributed to individual wall elements in proportion to their stiffness. It is therefore important to know the ratios between the stiffness of different types of

wall elements. Table 2 shows that the values of racking stiffness R are somewhat lower than the value of the initial stiffness K_i for all analysed elements. Therefore, in the design process, it is for the safe to consider the racking stiffness R , although the differences are only about 10%.

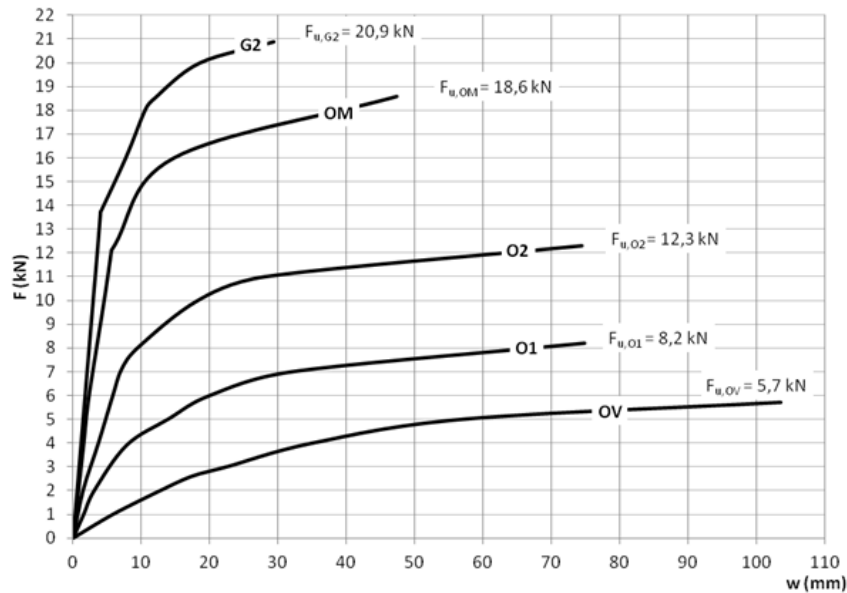

Fig. 5 F-w diagrams with the values of the ultimate capacity F_u

Table 2 The numerical values of the key behaviour indicators.

Element	Strength		Stiffness		
	F_{cr} [kN]	F_u [kN]	w_{cr} [mm]	$K_i = F_{cr} / w_{cr}$ [N/mm]	R [N/mm]
G2	13,7	20,9	4,00	3425	3333
OM	12,1	18,6	5,68	2130	2032
O2	7,1	12,3	7,07	1004	909
O1	3,9	8,2	7,79	501	440
OV	2,6	5,7	17,43	149	142

According to the distribution of the horizontal loads to individual elements and by knowing the values of the forces forming the first cracks (F_{cr}), the elastic resistance of a wall system may easily be determined. In a similar way, by knowing the ultimate capacities F_u , the collapse load of a wall system may be estimated. It is important to note, however, that the ultimate displacements (corresponding to the ultimate capacities F_u) are very large, especially in cases of the wall panels with openings. In real engineering structures such displacements would not be allowed. Moreover, as it is evident from Fig. 5, the values of the ultimate displacements are very different. Considering the fact, that the horizontal displacements at the top of a storey are constant along a wall (as a consequence of the diaphragm-function of the slabs), the values of F_u for different types of wall elements are not directly comparable. Consequently, using these values for the estimation of the ultimate capacity of a wall system would lead to inaccurate results.

For this reason it is important to define reasonable values of the ultimate (target) displacements which also set the values of the ultimate capacities. In order to prevent the damage to non-structural elements the limits on interstorey

drifts are given by the design codes. According to the European code for the design of earthquake-resistant structures, Eurocode 8 [21], the limitations are dependent on the type and the fixing of the non-structural elements and amount to 0,5% of storey height (for buildings having non-structural elements of brittle materials), 0,75% of storey height (for the case of ductile non-structural elements attached to the structure) and 1,0% of storey height (if the non-structural elements are fixed in a way so as not to interfere with structural deformations, and for buildings without non-structural elements). In our research, these values were adopted as the target displacements (w_t) for the definition of the corresponding forces F_{wt} .

Fig. 6 shows the determination of the forces F_{wt} for the case of the target displacement equal to 0,5% of storey height (i.e. $w_t = 13.2$ mm) and denoted as $F_{wt}^{0,5\%}$. Equivalently, the forces corresponding to different limitations of storey drifts, $F_{wt}^{0,75\%}$ (at $w_t = 19.8$ mm) and $F_{wt}^{1,0\%}$ (at $w_t = 26.4$ mm) were also determined. The numerical values are given in Table 3. Depending on the type and the attachment of the nonstructural elements, these values can be adopted as the ultimate capacities of the analysed wall elements.

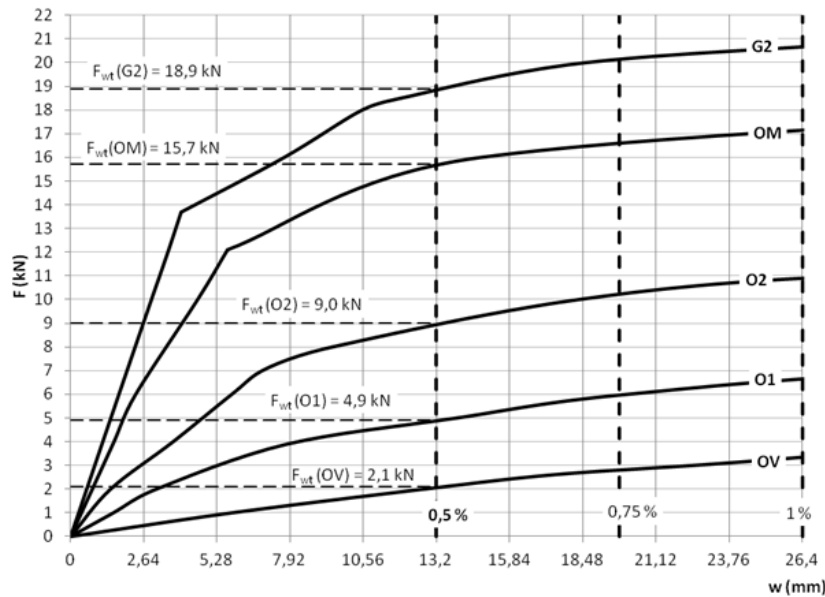

Fig. 6 F-w diagrams with the values of forces at the target displacement w_t (0.5% of storey height)

With a view of practical applicability, the relevant values from Tables 2 and 3 for the wall elements with openings (O1, O2, OM and OV) can be represented in the form of ratios normalized to the corresponding values of the full wall element (G2). In this way we obtain the strength and stiffness ratios, which will be discussed in the following section.

Table 3 The values of forces at the target displacements w_t

Element	$F_{wt}^{0.5\%}$ [kN]	$F_{wt}^{0.75\%}$ [kN]	$F_{wt}^{1.0\%}$ [kN]
G2	18,9	20,1	20,7
OM	15,7	16,8	17,9
O2	9,0	10,2	10,9
O1	4,9	6,0	6,6
OV	2,1	2,7	3,4

3. The strength and Stiffness Ratios as Functions of the Opening Coefficient (r)

Satisfactory coincidence between numerical and experimental results, see also [15], confirmed the relevance

$$\begin{aligned}
 & A_0 \dots \text{area of the opening} \\
 & \beta = \frac{\sum L_i}{L} \dots \text{wall length ratio} \\
 & r = \frac{1}{1 + \left(\frac{\alpha}{\beta}\right)} \dots \text{opening coefficient} \\
 & \alpha = \frac{A_0}{H \cdot L} \dots \text{opening area ratio}
 \end{aligned}$$

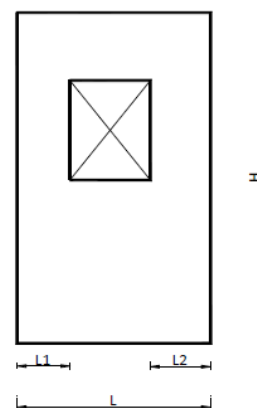

Fig. 7 Definition of the opening coefficient (r)

of the defined mathematical models to predict the behavior of the analysed wall panels. Due to the computational expense, however, these models are not very suitable for the analysis of large wall systems in the every-day engineering practice. In order to provide a procedure which enables simple but accurate calculation for the purpose of an efficient structural design, the discussed behaviour indicators of the wall panels are expressed using the so-called opening coefficient (r), introduced by Yasumura & Sugiyama [6]. The opening coefficient is calculated using the equations shown in Fig. 7.

In Table 4 the relevant values from Tables 2 and 3 are presented as ratios normalized to the corresponding values of the full wall panel (G2). The values of the opening coefficient were calculated according the equations from Fig. 7. The graphical presentation of the strength and stiffness ratios as functions of the opening coefficient (r) is given in Figs. 8, 9 and 10. The experimental results presented in [14] are for comparable reasons added to the ratios $K_i(r)$ and $F_{cr}(r)$.

Table 4 The strength and stiffness ratios

Element	r	$K_i(r)$	$R(r)$	$F_{cr}(r)$	$F_{wt}(r)^{0,5\%}$	$F_{wt}(r)^{0,75\%}$	$F_{wt}(r)^{1,0\%}$
G2	1,00	1,00	1,00	1,00	1,00	1,00	1,00
OM	0,80	0,62	0,61	0,88	0,83	0,84	0,86
O2	0,70	0,29	0,27	0,52	0,48	0,51	0,53
O1	0,50	0,15	0,13	0,28	0,26	0,30	0,32
OV	0,35	0,04	0,04	0,19	0,11	0,13	0,16

For each case a simple equation/function is proposed which can be used to calculate the relevant strength/stiffness ratios for a general value of the opening coefficient. As the values of the ratios for the initial stiffness (K_i) and the racking stiffness (R) are very similar (see Fig. 8), a general equation for the stiffness ratio $K(r)$ is proposed. In the same way, the ratios of the forces F_{wt}

show similar values for all considered cases of the target displacement (0,5% , 0,75% and 1% of the storey height) and thus a single function is proposed (see Fig. 10). As discussed in the previous section, this function is adopted as a general expression for the calculation of the strength ratios $F(r)$.

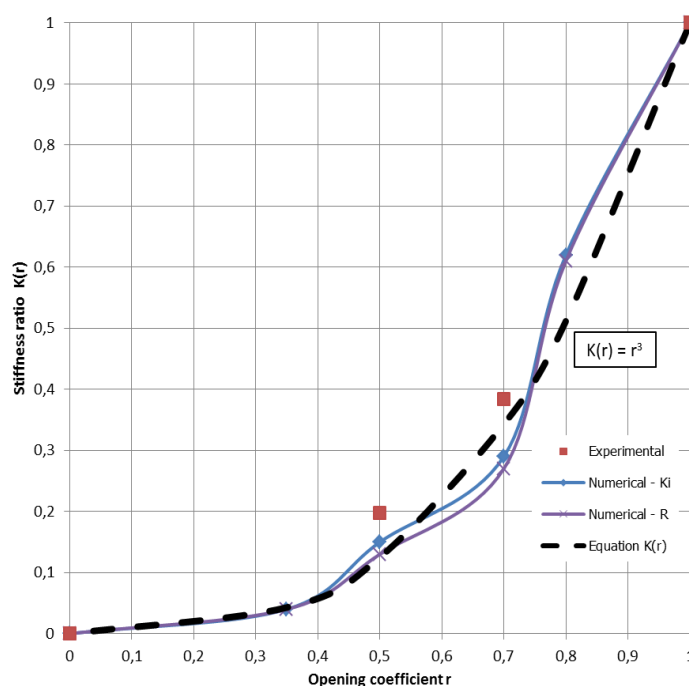

Fig. 8 $K(r)$ diagrams

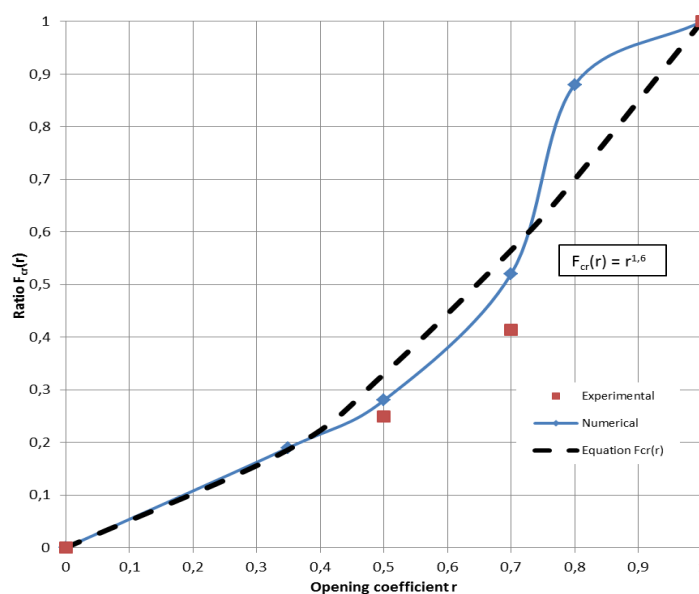

Fig. 9 $F_{cr}(r)$ diagrams

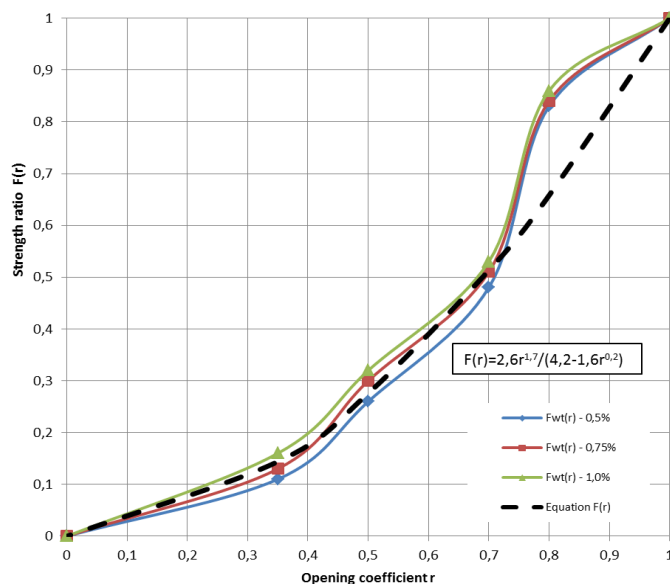

Fig. 10 F(r) diagrams

Knowing the behaviour of the corresponding full panel, which can be determined either by racking tests or e.g. by the mentioned analytical procedure introduced in [11], the key behaviour indicators can easily be calculated for a wall panel with an arbitrary area of the opening by using the diagrams presented in Figs. 8-10. Consequently, for a wall system composed from different types of wall elements, the distribution of the horizontal loads to individual elements (using the function $K(r)$ from Fig.8, the elastic resistance (using the function $F_{cr}(r)$ from Fig.9, as well as the ultimate capacity (using the function $F(r)$ from Fig.10 of the system can be estimated in a quick and efficient way.

The relatively low values of the stiffness ratios $K(r)$ indicate the fact, that the share of the horizontal loads transmitted to the panels with opening is small in comparison to the full panels. It should be noted, however, that in conventional buildings a large part (over 50%, but even up to 80%) of the walls may have openings. Thus, in a wall system the elements with openings may transmit a

considerable part of the horizontal loads. As the values of the ratios $F_{cr}(r)$ and $F(r)$ are higher than the stiffness ratios, the initial cracks in the sheathing boards can be expected to occur in the full wall elements, while the panels with openings remain elastic for some additional time. In this way, the elements with openings improve the post-elastic stiffness, the ultimate resistance as well as the so-called overstrength capacity of the structure.

For the purpose of a more detailed assessment of the results, the proposed functions for the calculation of the strength and stiffness ratios of the discussed FPB-sheated timber framed wall elements are compared to some previously discussed methods from literature, namely the Method B from Eurocode 5 [12], the strength/stiffness ratios for the plywood-sheated timber framed wall elements [6] and the strength/stiffness ratios for the solid cross-laminated wooden KLH panels with openings [16]. The comparisons are shown in Figs. 11 and 12.

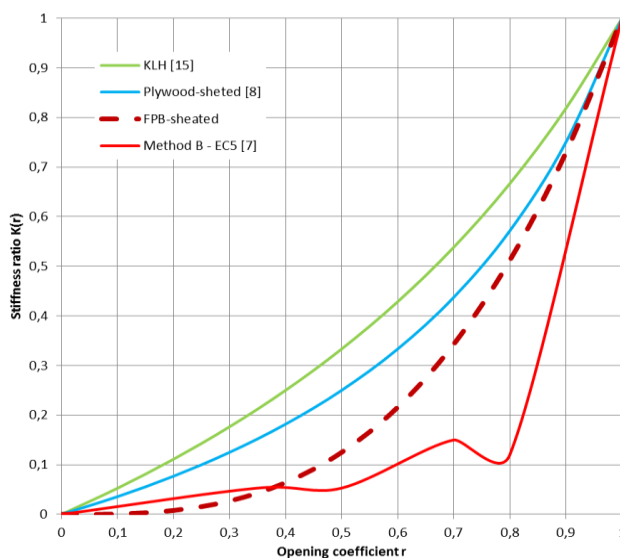

Fig. 11 Comparison of methods for the calculation of the stiffness ratio $K(r)$

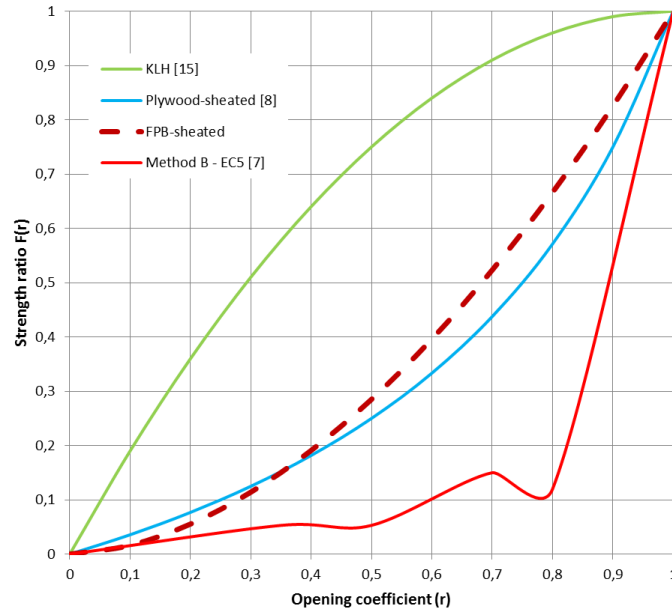

Fig. 12 Comparison of methods for the calculation of the strength ratio $F(r)$

From both comparisons the main deficiency of the Method B from Eurocode 5 is obvious, as the values of the ratios at $r = 0,7$ (panel O1) are lower than the values at $r = 0,8$ (panel OM). The unexpected jump occurs as a consequence of the fact, that the opening of the panel OM, although smaller, is wider than the opening of the panel O1. Consequently, as according to Method B only the parts of the panel beside the opening are considered, the calculated stiffness and capacity of panel O1 are higher than in the case of panel OM. Moreover, it can be seen that the values of both the strength and the stiffness ratios calculated by Method B are considerably lower when compared to the other methods. It can therefore be concluded that the actual contribution of the wall panels with openings to the overall capacity of the wall systems is underestimated significantly.

The differences between the remaining compared methods can be attributed to the specifics of behaviour of different types of wall panels. While the stiffness and the strength of the solid KLH panels is dependent only on the characteristics of the base material (i.e. its elastic modulus and compressive/tensile resistance), the behaviour of the plywood-sheated timber framed elements is governed mainly by the shear connection between the timber frame and the sheathing boards, which represents the weak component of the composite system. As mentioned above, in the case of the discussed FPB-sheated timber-frame wall panels the behaviour is mainly dependent on the relatively low tensile resistance and the consequent occurrence of cracks in the fiber plaster sheathing boards.

As expected, the results of the FPB-sheated timber-frame elements are most comparable to the results of the plywood-sheated elements [6]. However, the differences are still significant, especially in the case of the stiffness ratios (see Fig. 11). In general we can conclude that none of the comparative methods is suitable to be applied to the case of the FPB-sheated timber-frame wall panels.

4. Conclusions

A parametric numerical study on the horizontal load-bearing capacity of the FPB-sheated timber framed wall elements with openings is presented in the paper. Based on the results, the key behaviour indicators are presented as strength/stiffness ratios dependent on the opening coefficient. The proposed diagrams enable quick and efficient determination of the essential properties of wall elements with an arbitrary area of the opening and may thus represent a useful tool for the structural design process.

In conventional buildings a large part of the walls have openings and consequently the share of the horizontal loads transmitted to the elements with openings may be considerable. It seems reasonable, from both the economic and the technical points of view, that the contribution of these elements should be accounted for in the structural design process, of course by considering the realistic properties of their behaviour. A comparative study has shown that none of the methods that were previously developed for different types of wall elements can be accurately applied to the FPB-sheated panels. Due to their specific behaviour these elements require special consideration and represent a subject that needs to be improved in the current European design codes.

References

- [1] Kim HS, Lee DG. Analysis of shear wall with openings using super elements, *Engineering Structures*, 2003, Vol. 25, pp. 981-991.
- [2] Guan ZW, Zhu EC. Finite element modelling of anisotropic elasto-plastic timber composite beams with openings, *Engineering Structures*, 2009, Vol. 31, pp. 394-403.
- [3] Qamaruddin M. In plane stiffness of shear walls with openings, *Building and Environment*, 1999, Vol. 34, pp. 109-127.

- [4] Richard N, Yasumura M, Davenne L. Prediction of seismic behaviour of wood-framed shear walls with openings by pseudodynamic test and FE model, *Journal of Wood Science*, 2003, Vol. 49, pp. 145-151.
- [5] Yasumura M. Racking resistance of panel-sheathed shear walls with openings, *World Conference on Timber Engineering, WCTE, Riva del Garda, Trentino, Italy*, 2010.
- [6] Yasumura M, Sugiyama H. Shear properties of plywood-sheathed wall panels with opening, *Transaction of the Architectural Institute of Japan*, 1984, Vol. 338.
- [7] Dobrila P, Premrov M. Reinforcing methods for composite timber frame-fibreboard wall panels, *Engineering Structures*, 2003, No. 11, Vol. 25, pp. 1369-1376.
- [8] Premrov M, Dobrila P, Bedenik BS. Analysis of timber-framed walls coated with CFRP strips strengthened fibre-plaster boards, *International Journal of Solids and Structures*, 2004, Nos. 24-25, Vol. 41, pp. 7035-7048.
- [9] Premrov M, Kuhta M. Influence of fasteners disposition on behaviour of timber-frame walls with single fibre-plaster sheathing boards, *Construction and Building Materials*, 2008, Vol. 23, pp. 2688-2693.
- [10] Premrov M, Dobrila P. Modelling of fastener flexibility in CFRP strengthened timber-frame walls using modified γ – method, *Engineering Structures*, 2007, No. 2, Vol. 30, pp. 368-375.
- [11] Premrov M, Dobrila P, Bedenik BS. Approximate analytical solutions for diagonal reinforced timber-frame walls with fibre-plaster coating material, *Construction and Building Materials*, 2004, No. 10, Vol. 18, pp. 727-735.
- [12] CEN. Eurocode 5: Design of Timber Structures. Part 1-1: General rules and rules for buildings. EN 1995-1-1. Brussels, European Committee for Standardization, 2004.
- [13] Kozem Šilih E, Premrov M. Analysis of timber-framed wall elements with openings, *Construction and Building Materials*, 2010, No. 9, Vol. 24, pp. 1656-1663.
- [14] Kozem Šilih E, Premrov M. Influence of openings on horizontal load-carrying capacity of timber-frame wall elements with fibre-plaster sheathing boards, *Advances in Engineering Software*, 2012, No. 1, Vol. 43, pp. 19-26.
- [15] Kozem Šilih E, Premrov M, Šilih S. Numerical analysis of timber-framed wall elements coated with single fibre-plaster boards, *Engineering Structures [Print ed.]*, 2012, Vol. 41, pp. 118-125.
- [16] Šupek S, Dujič B, Žarnić R. Influence of openings on shear capacity of KLH walls. 30. zborovanje gradbenih konstrukterjev Slovenije, Bled, oktober 2008.
- [17] CSI. SAP2000 (v14.0.0) - Linear and nonlinear static and dynamic analysis and design of three-dimensional structures, Berkeley, Computer & Structures, Inc, 2010.
- [18] EN 594:2011: Timber Structures – Test methods – Racking strength and stiffness of timber frame wall panels, Brussels, European Committee for Standardization, 2011.
- [19] European Committee for Standardization. EN 338:2003 E: Structural timber – Strength classes. Brussels 2003.
- [20] Knauf Gipsfaserplatten Vidiwall und Vidifloor – company catalogue, 2002.
- [21] CEN. Eurocode 8: Design of structures for earthquake resistance - Part 1:General rules, seismic actions and rules for buildings, EN 1998-1. Brussels, European Committee for Standardization, 2005.