

Effects of blanket, drains, and cutoff wall on reducing uplift pressure, seepage, and exit gradient under hydraulic structures

H. Khalili Shayan¹, E. Amiri-Tokaldany^{2,*}

Received: November 2013, Revised: June 2014, Accepted: November 2014

Abstract

Upstream blankets, drains and cutoff walls are considered as effective measures to reduce seepage, uplift pressure and exit gradient under the foundation of hydraulic structures. To investigate the effectiveness of these measures, individually or in accordance with others, a large number of experiments were carried out on a laboratory model. To extend the investigation for unlimited arrangements, the physical conditions of all experiments were simulated with a mathematical model. Having compared the data obtained from experiments with those provided from the mathematical model, a good correlation was found between the two sets of data indicating that the mathematical model could be used as a useful tool for calculating the effects of various measures on designing hydraulic structures. Based on this correlation a large number of different inclined angles of cutoff walls, lengths of upstream blankets, and various positions of drains within the mathematical model were simulated. It was found that regardless of their length, the blankets reduce seepage, uplift pressure and exit gradient. However, vertical cutoff walls are the most effective. Moreover, it was found that the best positions of a cutoff wall to reduce seepage flow and uplift force are at the downstream and upstream end, respectively. Also, having simulated the effects of drains, it was found that the maximum reduction in uplift force takes place when the drain is positioned at a distance of 1/3 times the dam width at the downstream of the upstream end. Finally, it was indicated that the maximum reduction in exit gradient occurs when a drain is placed at a distance of 2/3 times of the dam width from upstream end or at the downstream end.

Keywords: Cutoff wall, Blanket, Drain, Uplift pressure, Seepage, Exit gradient.

1. Introduction

For hydraulic structures constructed on permeable foundations, the difference of water levels between upstream and downstream sides of these structures, seepage occurs under the foundation of these structures. The effects of seepage on the foundation of hydraulic structures can be classified into three parts: uplift force, seepage discharge and exit gradient. Uplift force reduces the shear resistance between structure and its foundation, causes a reduction in stability of the structure against sliding or overturning. Increasing the seepage velocity at the downstream end of hydraulic structures, may cause the movement of soil particles and accordingly accelerates piping and soil erosion.

The exit gradient is the main design criterion in determining the safety of hydraulic structures against the piping phenomenon.

Bligh [1] was the first who introduced the creep length theory for the flow passing under hydraulic structures. Bligh defined the creep length as the route of the first line of seepage which is in contact with the structure's foundation. Assuming that the hydraulic gradient is constant along the creep line, Bligh [1] stated that the energy loss along this path varies linearly with creep length and hence, uplift pressure distribution is linear. Lane [2] based on his investigation of over 200 damaged hydraulic structures, reported that there is a difference between horizontal and vertical creep paths and consequently, presented his weighted creep theory with assigning coefficients of 0.33 and 1.0 for total horizontal and vertical percolation lengths, respectively. Using Schwarz-Christoffel transformation method to weir design of a certain type, and considering a flat foundation type, with its ellipse-shaped flow lines, and with hyperbolas, as equipotential, Khosla et al. [3] presented a method to determine the uplift pressure distribution under foundation of hydraulic structures. The other method to estimate uplift pressure under hydraulic structures is based on solving Laplace Equation (LE) as a predominant equation in steady conditions. This method presents an exact solution for solving cases with different boundary conditions. However, the equation is difficult for engineering applications and will include difficult integrals when a

* Corresponding author: amiri@ut.ac.ir

¹ PhD Student, Irrigation and Reclamation Engineering Department, University of Tehran, P.O. Box 31587-4111, Karaj, Iran 31587-77871

² Associate Professor, Irrigation and Reclamation Engineering Department, University of Tehran, P.O. Box 31587-4111, Karaj, Iran 31587-77871

cutoff wall or a change in extent of seepage flow is introduced (Harr, [4]). Pavlovsky [5,6] provided analytical solutions for two cases of finite-depth seepage: flat aprons with a single cutoff, and depressed floors without cutoffs. His work, originally in Russian, was later published in English (Leliavsky [7]; Harr [4]; Polubarinova-Kochina [8]). Fil'chakov [9, 10] studied (analytically) finite-depth seepage that included several schemes of weirs with cutoffs. Abedi Koupaei [11] in a case study calculated the distribution of uplift pressure using the four above mentioned methods. Koupaei [11] stated that the amount of uplift pressure estimated by using Bligh [1] and Lane [2]'s theories is less than both Khosla et al. [3] and Finite Difference Methods (FDM). Griffiths and Fenton [12] by combination of the techniques of random fields generating with the Finite Element Method (FEM), tried to model the 3D steady seepage in which the permeability was randomly distributed within the soil body. Opyrchal [13] presented the application of the fuzzy concept to identify the seepage path within the body of a dam. Sedghi asl et al. [14] using the FDM studied the effects of the position of a cutoff wall on reducing seepage and flow velocity under hydraulic structures and they found that the best position for the cutoff wall is at the upstream and downstream ends, respectively. Rahmani Firoozjaee and Afshar [15] presented a truly meshless method namely, discrete least square method (DLSM) for the solution of free surface seepage problem. The application of this method was shown for free surface problem for a porous media. The results show a good approximation for both regular and irregular nodes positioning. Ahmed and Bazaraa [16] investigated 3D seepage flow below and around hydraulic structures by using a Finite Element Model. They compared the results of 3D analyses with 2D analyses for estimating exit gradient, seepage flow and uplift force. With the aim of reducing seepage losses through canal banks and designing stable hydraulic structures, Ahmed [17] investigated the effects of different configurations of sheet pile on the reduction of uplift force, seepage flow and exit gradient. Based on Ahmed [17]'s result, it is recommended to construct a clay (or a very low permeable soil) core at the inner edge of the banks. Sedghi asl et al. [18] based on a laboratory study, recommended some criteria to determine the optimum length of blanket and height of cutoff walls to produce minimum uplift pressure against protective dikes. Using Schwarz-Christoffel transformation equations, Jain and Reddi [19] provided Closed-form theoretical solutions for steady seepage below a horizontal impervious apron with equal end cutoffs. Zainal [20] investigated the effects of cutoff wall on seepage under dams and concluded that the best angle to minimize the seepage discharge, uplift pressure, and exit gradient is about 60° , 120° to 135° , and 45° to 75° , respectively. Jafarieh and Ghannad [21] investigated the effect of foundation uplift on elastic response of soil-structure system. They showed that in general foundation uplift force reduces the drift response of structures. They found that the reduction is about 35 percent for slender structures located on relatively soft soils. Heidarzadeh et al. [22] reported an engineering

experience about well installation under high artesian flow condition at the downstream of Kharkheh earth dam in Iran. They showed that with installation the new relief wells, the safety factor of the downstream toe increases to a safety value of 1.3 for the normal head reservoir. Also, after installation of the new relief wells, the drainage discharge from the conglomerate layer increased from 35 lit/s to around 900 lit/s.

In this research, using a laboratory model, the effects of cutoff wall's angle on the amount of uplift force, seepage, and exit gradient were investigated. Also, the effects of upstream blanket and the position of drains on the amount of these articles were evaluated.

2. Experimental Specifications and Procedure

2.1. Laboratory setup

In order to evaluate the effects of cutoff wall on uplift pressure, seepage discharge and exit gradient, an experimental program was carried out in an available flume of 18 cm wide and 210 cm length located in the Hydraulic Laboratory of the Department of Irrigation and Reclamation Engineering, University of Tehran. Other dimensions of the flume and the positions of the cutoff wall are shown in Fig. 1. The impermeable cutoff wall with depths of 2.5, 5, 10, 15, 20, 25 and 30 cm was individually installed at the upstream and downstream ends of the dam's model, and at the 55, 70, 85, 100, 115 cm from the beginning of the dam's model ($x = 0, 15, 30, 45, 60, 75, \text{ and } 90$ cm). The upstream head water with respect to the top of sand body (h) was taken as 2.5, 5, 7.5, 10, 12.5, 15 and 20 cm which be held constant during each test. The downstream water level is set to zero (equal to the top of the sand body) and the distribution of uplift pressure was determined by using a piezometric network consisted of 39 piezometers (13 rows with 3 piezometers per row). In each experiment, the same type and volume of soil was poured into the flume, spread, and compacted. To prevent piping, a gravel filter layer ($D_{50}=2$ mm) was poured on both upstream and downstream sides. Beach sand ($D_{50}=0.75$ mm), considered as the most unsuitable type of soil from the stability point of view for hydraulic structures, was selected as permeable bed material.

The hydraulic conductivity of soil in vertical direction was estimated as 0.0012 m/s by using the constant head method. As there is no practical method to measure the hydraulic conductivity in horizontal direction, the dye injection method was used to estimate the resultant hydraulic conductivity. Given the resultant magnitude of hydraulic conductivity and its known value in vertical direction, the soil permeability in horizontal direction was estimated as 0.0014 m/s. In total, one hundred and ten experiments were conducted under various conditions of upstream heads, cutoff wall depths, and cutoff wall positions. In each experiment, seepage was measured by using the volumetric method. Also, uplift pressure distribution along the base of the dam was obtained from the piezometric network.

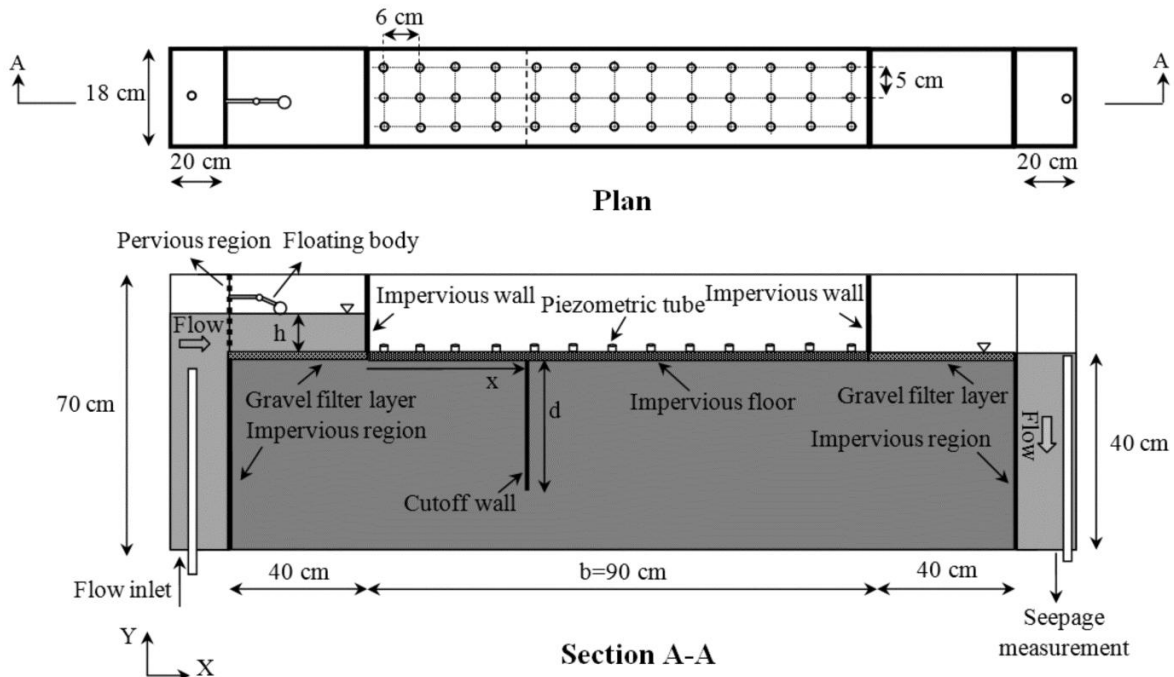

Fig. 1 (a) Dimensions of the physical model and cutoff wall positions, (b) Plan view of piezometric network

2.2. Fundamental equations applied in analysis

Seepage differential equation can be obtained from the combination of Darcy's formula and Continuity Differential Equation as (Harr, [4]):

$$\frac{\partial}{\partial x} \left(k_x \frac{\partial h_{(x,y,t)}}{\partial x} \right) + \frac{\partial}{\partial y} \left(k_y \frac{\partial h_{(x,y,t)}}{\partial y} \right) + Q = \frac{d\theta_v}{dt} \quad (1)$$

in which $h_{(x,y,t)}$ = total head at a point with coordinates of (x,y) , θ_v = volumetric water content, k_x and k_y = hydraulic conductivity of soil in horizontal and vertical directions, respectively, and Q = the produced discharge rate per unit area of the element ($Q < 0$ when a drain is present). In steady state and for isotropic soil (i.e. $k_x = k_y$) and the absence of any drains, Eq. (3) is simplified into:

$$\left(\frac{\partial^2 h_{(x,y,t)}}{\partial x^2} \right) + \left(\frac{\partial^2 h_{(x,y,t)}}{\partial y^2} \right) = 0 \quad (2)$$

This differential equation can be solved, subject to the appropriate boundary conditions, by the finite element method (FEM) (Zienkiewicz, [23]). In this study, to solve Laplace's Equation which governs the steady flow in porous media, the sub-program of SEEP/W (a part of GEOSTUDIO 2007 software package) based on the FEM

was used (Krahn, [24]). The results are presented in following section.

3. Results and Discussion

3.1. Validation of numerical method by experimental data

In Fig. 2-a, the results of total uplift force obtained from FEM versus the experimental results are indicated. Also, Fig. 2-b shows seepage calculated by FEM versus experimental data. Correlation coefficient (R^2) and Mean Standard Error (MSE) were used to quantify the fit, see below:

$$R^2 = 1 - \frac{\sum_{i=1}^n (x_i - \hat{x}_i)^2}{\sum_{i=1}^n (x_i - \bar{x})^2} \quad (3)$$

$$MSE = \frac{1}{n} \sum_{i=1}^n (x_i - \hat{x}_i)^2 \quad (4)$$

in which x_i = observed data, \hat{x}_i = calculated data and \bar{x} = average of observed data. Results in Figs. 2-a and 2-b indicate a good fit between FEM and experiments in estimating uplift pressure and seepage discharge. Based on these results the analysis was proceed using the FEM.

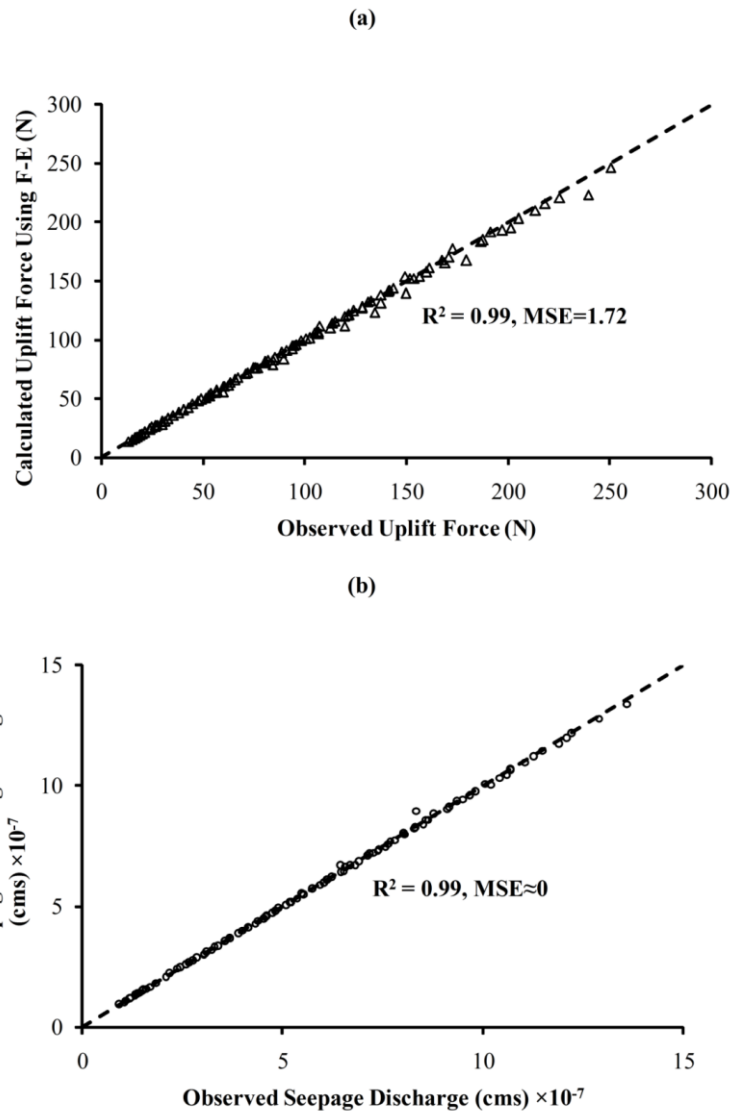

Fig. 2 Evaluation of F-E method for estimating a) Uplift force, b) Unit seepage discharge

3.2. The effects of the depth and the location of vertical cutoff walls on seepage discharge

To evaluate the effects of the depth and the location of vertical cutoff walls on seepage discharge, using the results of laboratory model, a set of non dimensional curves are provided in Fig. 3-a. Based on the experimental data in Fig. 3-a, it can be seen that:

1) Given a certain depth for cutoff wall, by moving the along the floor from upstream to the middle of the floor, seepage discharge increases so that it reaches to its maximum value in the middle of the floor. By moving the cutoff wall from the middle to downstream end, seepage discharge gradually decreases and the minimum seepage discharge will be obtained when the cutoff wall is at the downstream end. Thus, the best position of a cutoff wall for maximum reduction of seepage discharge is at the downstream end.

2) Given a certain position of cutoff wall, increasing the cutoff depth results in a reduction in the seepage discharge. Based on Darcy's theory, this phenomenon can be understood by increasing "creepage" length and thus a

decreasing average hydraulic gradient. Moreover, as the opening between the cutoff wall end and the impervious floor is reduced, converging flow lines add resistance to flow and seepage is reduced.

In Fig. 3-b, a non dimensional curve is introduced to show the amount of seepage discharge per unit width of the dam for the same head (h) and hydraulic conductivities in vertical and horizontal directions but without cutoff wall. The curve in Fig. 3-b can be used to estimate the basic seepage discharge for individual layers when no cutoff wall is used to reduce the seepage discharge. Moreover, using three-fourth of the measured data, the following empirical equation can be obtained through a regression analysis of the laboratory data to estimate the seepage discharge per unit width (q_0):

$$q_0 = \frac{kh}{1.05 \frac{b}{D} + 0.806} \quad (5)$$

Moreover, using the same data, Eq. (6) is introduced to

estimate seepage discharge for different positions and depth of cutoff walls under dam foundation.

$$\frac{q}{q_0} = -0.47\left(\frac{x}{b}\right)^2 + 0.413\left(\frac{x}{b}\right) - 0.456\frac{d}{D} + 1 \quad (6)$$

The parameters used in Eq. (6) are defined in Fig. 4. To evaluate Eq. (6), in Fig. 3-c the amounts of seepage discharge calculated from Eq. (6) are compared with those obtained from the remained one-fourth of the experimental results. The corresponding magnitudes of R^2 (0.959) and MSE (0.00015) in Fig. 3-c shows a reasonable agreement between two sets of data illustrates that Eq. (6) can be used to estimate seepage discharge with acceptable accuracy.

Moreover, the effects of cutoff wall's depth and

situation on seepage discharge, are evaluated using both the analytical results of Harr [4] and the present study (Fig. 3-d). From Fig. 3-d it can be seen that Harr's [4] method does not distinguish the effect of cutoff wall's situation in the left and right halves of the floor. Consequently, Harr's [4] method gives the same values of seepage discharge affected by a certain cutoff wall which located at the upstream or downstream end. This is clearly inconsistent with the experimental data and can be easily explained this discrepancy in terms of the flow lines. Fig. 3-d shows a good agreement between two methods on estimating the seepage discharge at the presence a cutoff wall in the left half of the floor. Nevertheless, the present study underestimates the values of seepage discharge for locating a cutoff wall at the right half. The discrepancy has its maximum magnitude at the downstream end.

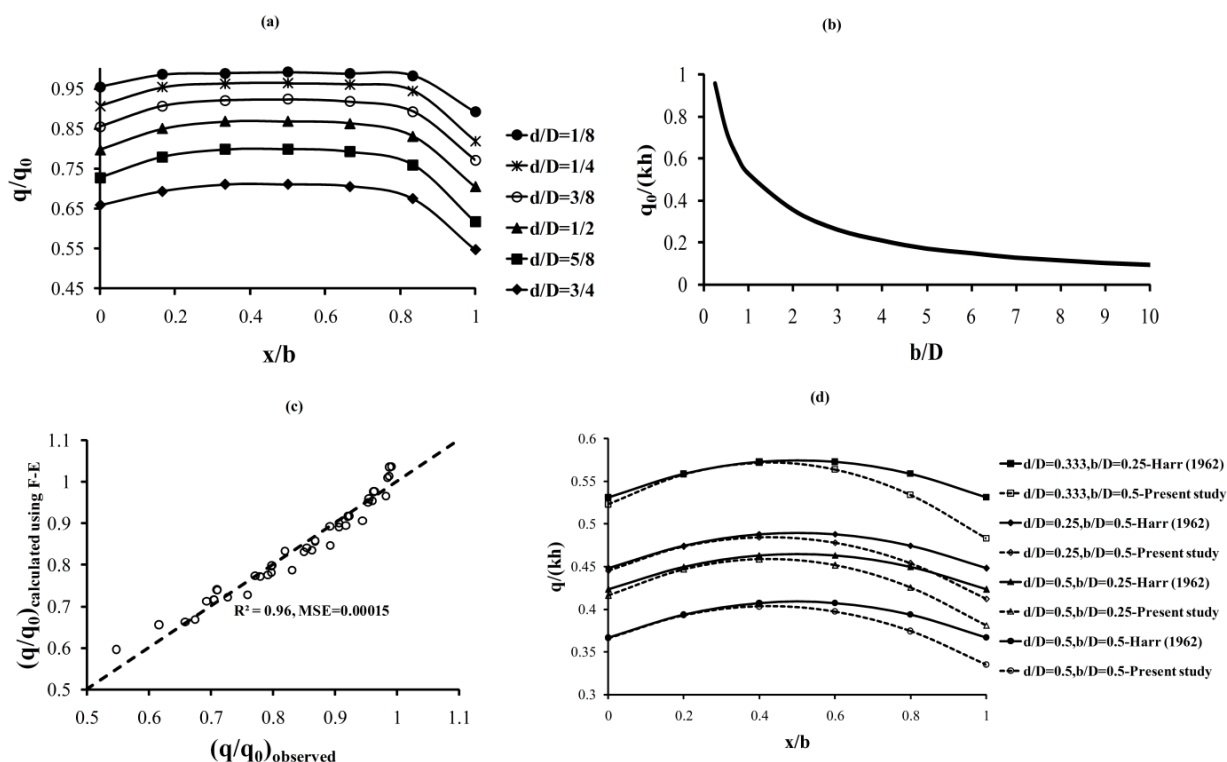

Fig. 3 (a) Effects of depth and position of cutoff wall on seepage discharge (from experimental data), (b) Determination of unit seepage discharge in the absence of cutoff wall, blanket or drain (from numerical data), (c) Comparison between unit seepage discharge from Eq. (6) with the experimental data, (d) Comparison between unit seepage discharge from Eq. (6) with the Harr [4] data

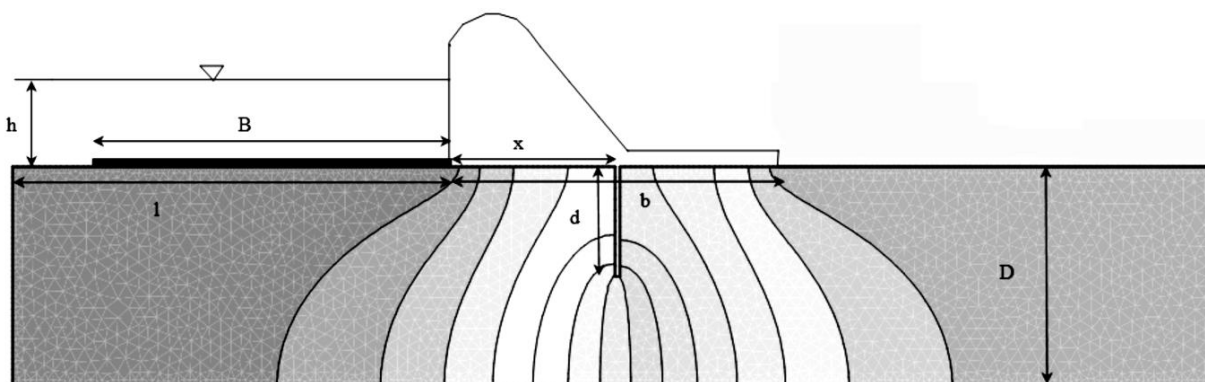

Fig. 4 Definition of parameters

3.3. The effects of the depth and the location of vertical cutoff walls on exit gradient

The hydraulic gradient at the downstream end of the first percolation trajectory is important because in this point the particles of the filtering water leave the granular soil and emerge into the free water of the downstream channel. The stability of the granular soil depended on the limiting value of the hydraulic gradient at the upper surface of the granular material, which gradient was to be smaller than critical gradient. This limiting gradient is described as exit gradient by Khosla et al. [3] (Leliavsky, [7]). To calculate the exit gradient for different points of various structures, Khosla et al. [3] obtained relationships theoretically by differentiating the pressure with respect to the ordinate and introduced different equations to calculate exit gradient at different points of hydraulic structures (Leliavsky, [7]). The exit gradient in Khosla et al. [3]’s method is given by (Leliavsky, [7]):

$$\frac{i.d}{h} = \frac{1}{\pi\sqrt{Y}} \tag{7}$$

where $Y = \frac{1 + \sqrt{1 + \alpha^2}}{2}$ in which $\alpha = \frac{b}{d}$.

In this research, considering the geometry of an experimental model, F-E method is used to estimate exit gradient at different positions of cutoff wall under the dam foundation. Using the results, in Fig. 5 a set of non dimensional curves is introduced to use the amount of exit gradient for different positions and various cutoff walls along the foundation. As shown in Fig. 5-a, the exit gradient has its minimum value when the cutoff wall is located at the downstream end. For the most cases, the exit gradient is increased from the upstream end toward the downstream end and is reduced to its minimum value at the downstream end. Moreover, as expected, the exit gradient is decreasing as the depth of cutoff is increasing. Note that in Fig. 5, i = exit gradient in the presence of cutoff wall and i_0 = exit gradient in the absence of cutoff wall (Fig. 5-b).

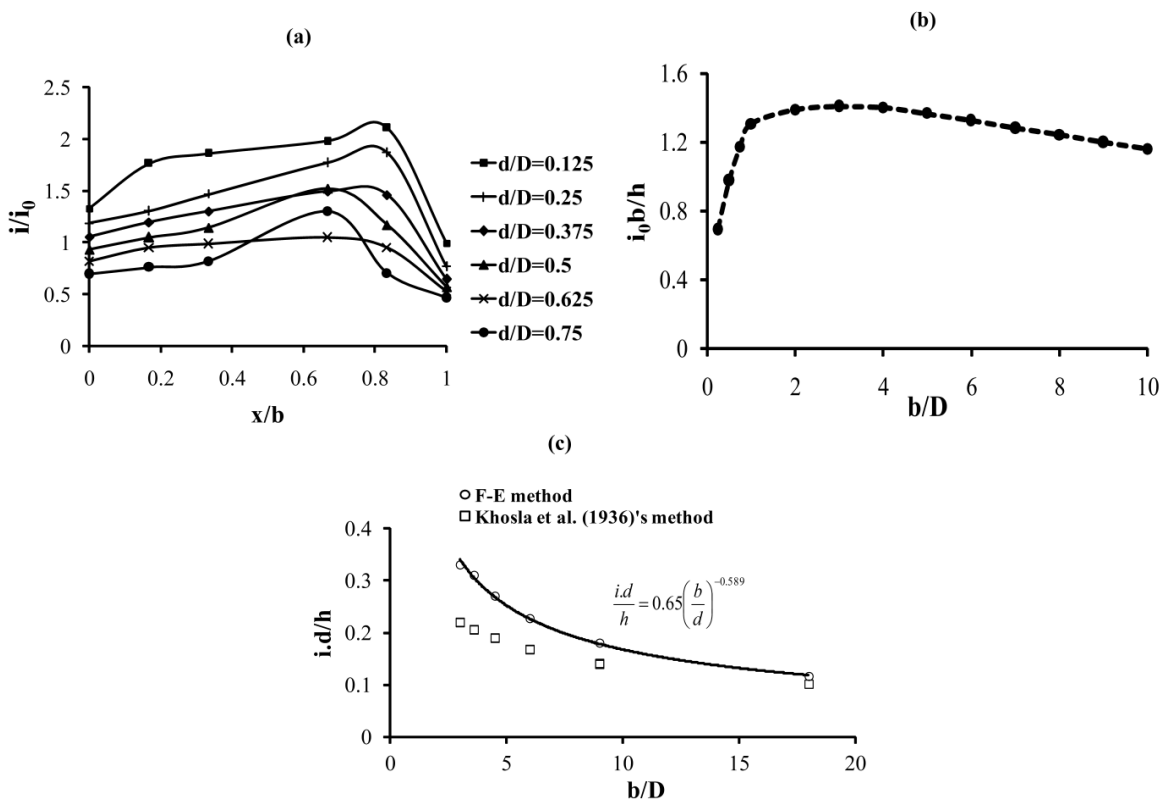

Fig. 5 (a) Effects of depth and position of cutoff wall on exit gradient, (b) Determination of exit gradient under cutoff wall, (c) Estimated exit gradient by using Khosla et al. [3] and F-E method

For further investigation of the accuracy of Khosla et al. [3]’s method; i.e. Eq. (7), on estimating the exit gradient, first of all it should be noted that for the case when there is no cutoff wall at downstream end; i.e. $d \rightarrow 0$, the exit gradient is infinite. So, to compare the results of Khosla et al. [3]’ method with those obtained from F-E, a cutoff wall was considered at downstream end with various heights of 10, 15, 20, and 30 cm under the

upstream fixed head of 2.5, 5, 7.5, 10, 12.5, 15, 17.5 and 20 cm. The following equation similar to Khosla et al. [3]’s equation can be obtained through a regression analysis of the numerical model data:

$$\frac{i.d}{h} = \frac{1}{\pi\sqrt{Y}} = 0.65 \left(\frac{b}{d}\right)^{-0.589} \rightarrow Y = 0.24 \left(\frac{b}{d}\right)^{1.178} \tag{8}$$

To evaluate the new equation, the results obtained from F-E method were compared with those obtained from Khosla et al. [3]'s method (Fig. 5-c). As shown in Fig. 5-c, the results obtained from Eq. (8) are bigger (maximum 30%) than those obtained from Khosla et al. [3]'s method. The difference is maximum for lower values of α but it tends to be zero for long blankets.

3.4. The effects of the depth and the location of vertical cutoff walls on uplift force

In order to evaluate the effects of the depth and the position of cutoff wall's on uplift force, a cutoff wall with a constant height was installed at the upstream end, moving toward the downstream end (Fig. 1) while the amount of uplift pressure were taken by piezometers installed inside the flume. This is repeated for other heights of cutoff wall. Uplift forces were estimated by the integration of uplift pressure distribution using Simpson's 3/8 rule. Fig. 6-a shows that by moving the position of cutoff wall from upstream end of the blanket toward downstream, uplift force increases so that it's minimum and maximum values has been found at the upstream and

downstream ends, respectively.

Using a part of results (two-third) obtained from the laboratory experiments, an equation is introduced to estimate the relative changes of uplift force under a dam foundation affected by installing a simple, individual cutoff wall with different heights at different positions under dam foundation (Eq. 9).

$$\frac{F_p}{F_{p0}} = \frac{(2.205 + x/b)}{(2.205 - 1.315d/D)} - 1.588d/D \quad (9)$$

where F_{p0} is uplift force in the absence of cutoff wall, blanket or drain. Similarly, using the remained results (one-third), the amount of uplift force calculated from Eq. (9) is compared with those obtained from the experimental results (Fig. 6-b). The corresponding magnitudes of R^2 (0.923) and MSE (0.005) in Fig. 6-b shows a reasonable agreement between two sets of data illustrates that Eq. (9) can be used to estimate uplift force with acceptable accuracy.

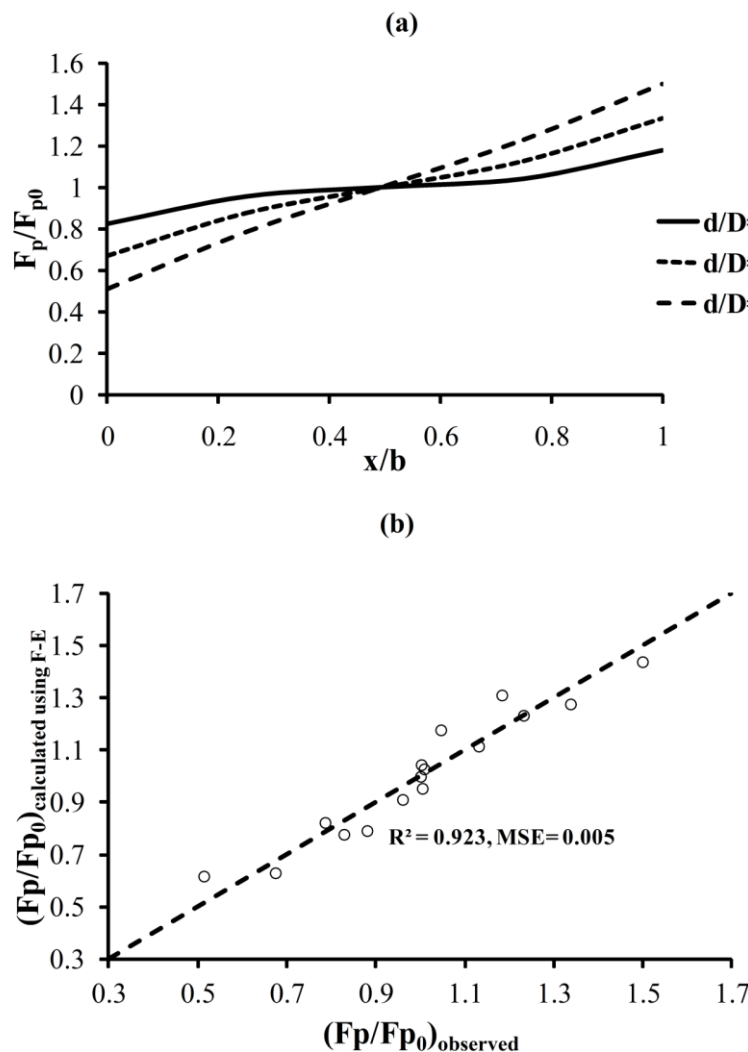

Fig. 6 (a) Dimensionless diagram used for changes of uplift force by position of cutoff wall, (b) Comparison between uplift forces from Eq. (9) with experimental data

3.5. The effects of inclined angle of cutoff wall on seepage discharge, exit gradient, and uplift force

Zainal [20] for a case study investigated the optimal inclined angle for a cutoff wall. However, he did not consider the effects of the depth and the location of the cutoff walls on the optimal inclined angle. Based on the conclusion obtained in previous sections, in order to investigate the effects of inclined cutoff wall on reducing the magnitude of seepage discharge, exit gradient, and uplift force, the laboratory model was simulated in GEOSTUDIO 2007 software. Cutoff walls were considered at the upstream end, at the distances of 15 and 30 cm far from the upstream end, at the middle, and at the

end of the floor. In each position, three values of d/D ratios (in which d = cutoff wall depth and D = thickness of pervious soil) of 0.25, 0.50 and 0.75 were considered and for each case, cutoff wall was located at 30, 45, 60, 90, 120 and 150 degrees to the horizon (See Fig. 7). Using the software, the magnitude of uplift force, seepage discharge and exit gradient for each case were computed. An example of the graphical results obtained from the model is shown in Fig. 7. In Fig. 8 the effects of inclined angle, the depth, and the location of a single cutoff wall on the reduction of seepage discharge for h/D equal to 0.25 is shown.

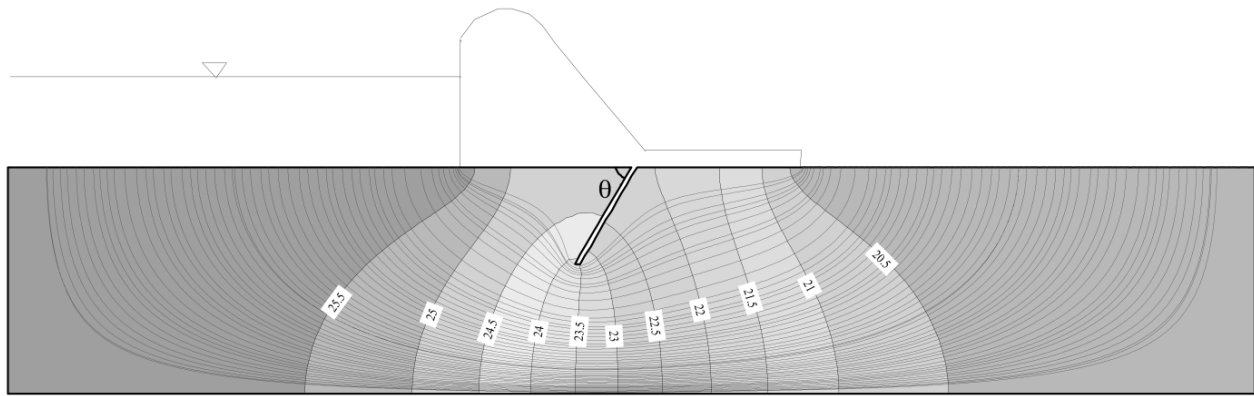

Fig. 7 Results from the numerical model for the inclination angle of 60 degrees

Fig. 8-a indicates the effects of a short cutoff wall (d/D equal to 0.25) on reducing seepage discharge while Figs. 8-b and 8-c show the effects for d/D equal to 0.5, and 0.75, respectively. As shown in Fig. 8-a the effects of a short-inclined cutoff wall positioned around the middle of the dam (from $x/b = 0.25$ to $x/b = 0.75$) on the reduction of seepage flow is negligible, but the effects are significant for both positions of the upstream and downstream ends and varies according to the different wall angles; i.e. 60 degrees when cutoff wall positioned at upstream end and 120 degrees for cutoff wall positioned at downstream end. Figs. 8-b and 8-c show that the most reduction of seepage flow take places for the inclined angles around 90 degrees indicates that the best angle for medium to long cutoff walls is 90 degrees. Consequently, the best position of cutoff wall is depending on inclined angle. Although the best position of the cutoff wall to control seepage is at the end of downstream blanket, but locating the cutoff wall with inclined angles less than 60 degrees in upstream position have more effect on

decreasing seepage discharge in comparison with downstream cutoff.

Similarly, in Fig. 9, the effects of inclined angle, the depth, and the location of a single cutoff wall on the exit gradient is shown. Fig. 9-a shows the effects of a short cutoff wall ($d/D = 0.25$) on reducing exit gradient while Figs. 9-b and 9-c show the effects for $d/D = 0.50$, and $d/D = 0.75$, respectively. As shown in Fig. 9 there is a significant reduction of exit gradient when the cutoff wall is positioned at the downstream end for inclined angle of 90 degrees or more. Moreover, Fig. 9-a illustrates that there is no significant reduction of exit gradient for short cutoff walls when they are positioned before the downstream end, regardless of the inclined angle of cutoff wall. By increasing the depth of the cutoff wall, the reduction of exit gradient increases when the cutoff wall comes close to the downstream end, thus confirming the downstream end as the best position of cutoff wall to decrease the magnitude of exit gradient.

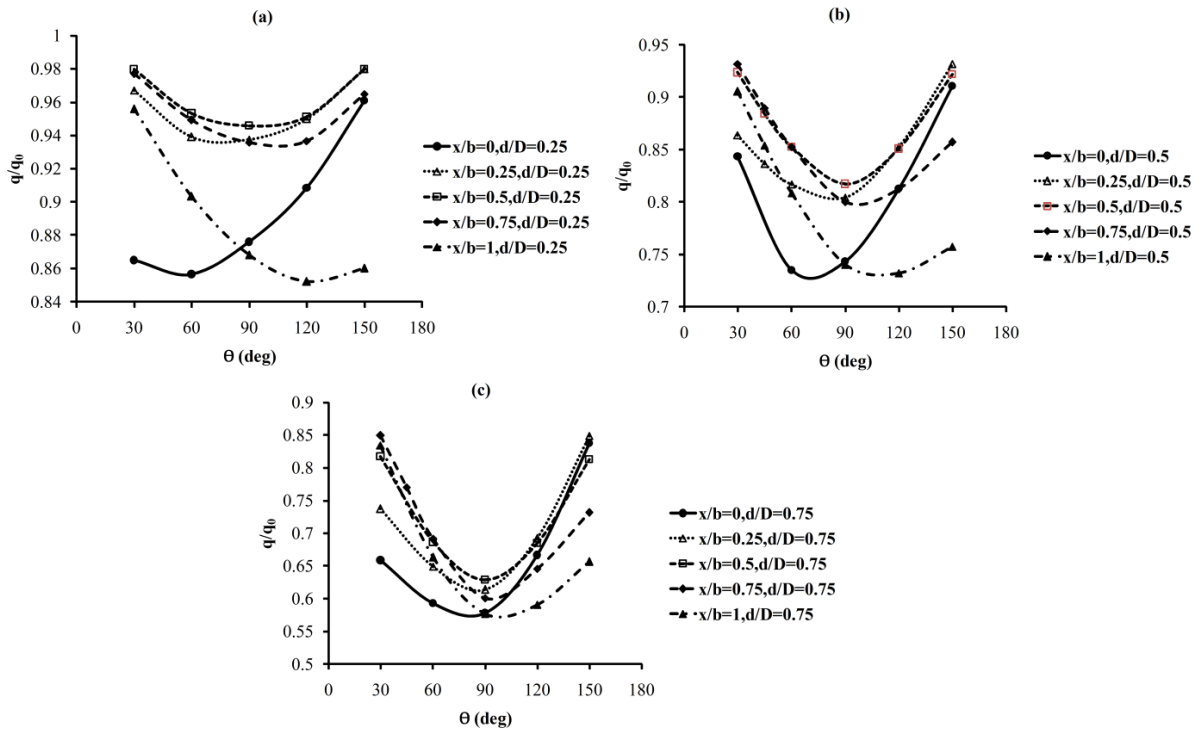

Fig. 8 Effect of Cutoff wall situation and inclined angle on seepage discharge for $\frac{h}{D} = 0.25$ (a) Short cutoff wall, (b) Medium cutoff wall, (c) Long cutoff wall

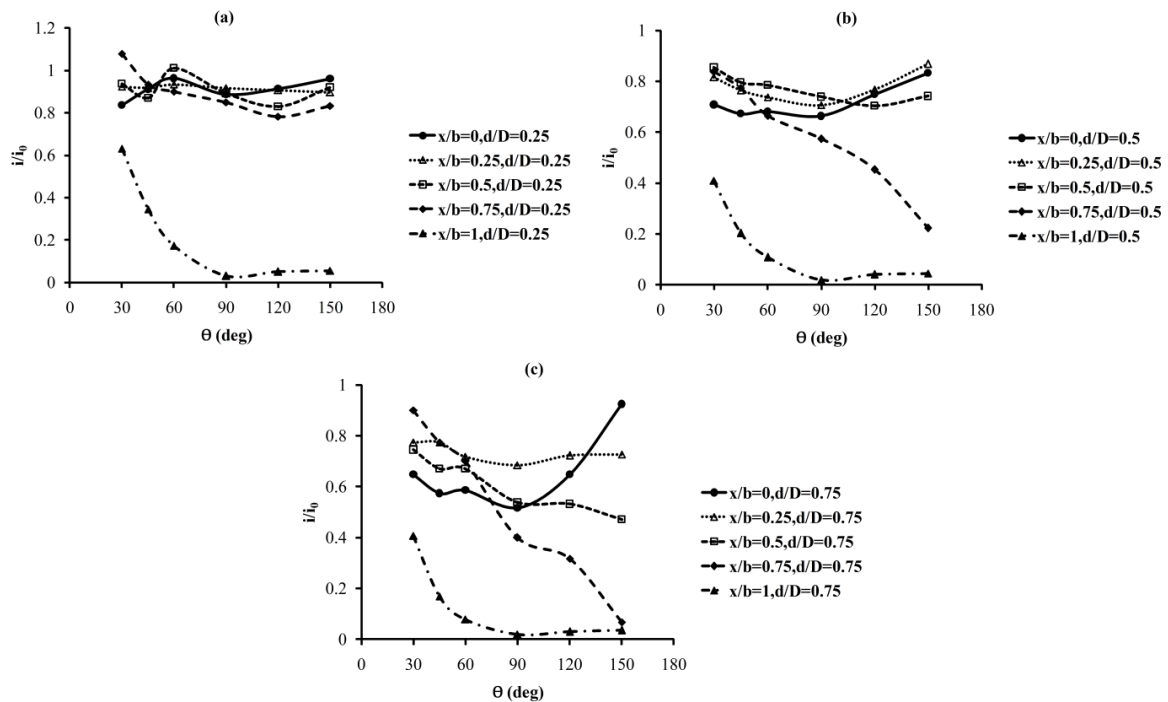

Fig. 9 Effect of Cutoff wall situation and inclined angle on exit gradient for $\frac{h}{D} = 0.25$ (a) Short cutoff wall, (b) Medium cutoff wall, (c) Long cutoff wall

In Fig. 10 the effects of inclined angle, the depth, and the location of a single cutoff wall on uplift force is shown. Figs. 10-a, 10-b and 10-c show the effects of a short ($d/D = 0.25$), medium ($d/D = 0.5$), and long

($d/D = 0.75$) cutoff walls on reducing uplift force, respectively. Fig. 10 shows that the most effective position of a cutoff wall to reduce uplift force is at the upstream end. Fig. 10 indicates that using cutoff wall with inclined

angle not only results in no reduction of uplift force in the downstream middle of the blanket. Also, presence of the short cutoff wall with the inclined angle of 60 degrees at the upstream of the blanket causes insignificant decreasing of uplift force.

Finally, in Fig. 11, the amount of reduced seepage flow, exit gradient, and uplift force estimated for different inclined cutoff walls are shown as a percentage of the

amount of those parameters for vertical cutoff wall when $h/D = 0.25$ and $d/D = 0.75$. Fig. 11 illustrates that in most cases, the inclined cutoff walls result in more seepage flow, exit gradient, and uplift force than vertical walls. However, optimum inclined angle depends on the position and the length of cutoff wall. So, no general conclusion about the optimal inclination of a cutoff wall can be drawn.

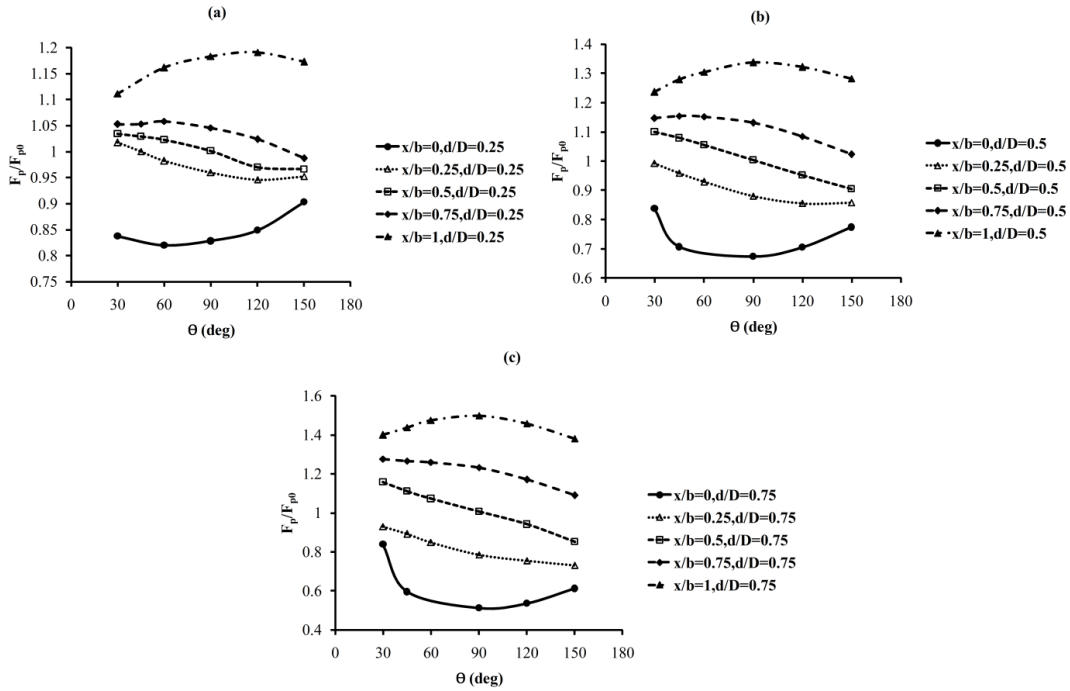

Fig. 10 Effect of Cutoff wall situation and inclined angle on uplift force for $\frac{h}{D} = 0.25$ (a) Short cutoff wall, (b) Medium cutoff wall, (c) Long cutoff wall

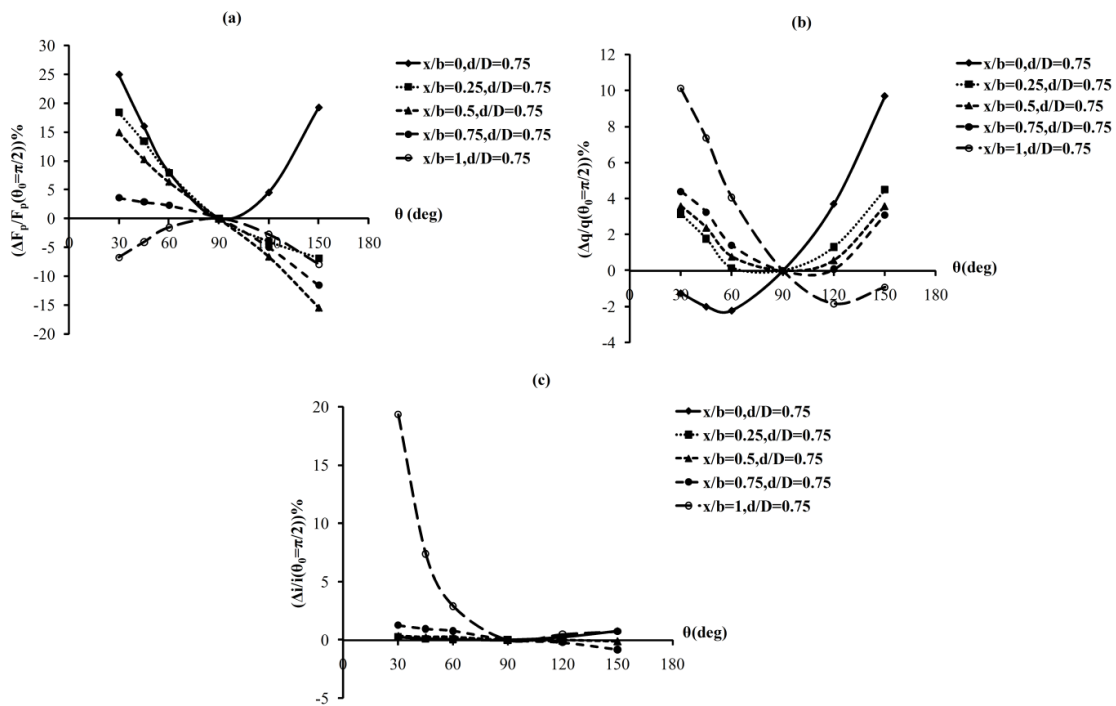

Fig. 11 Comparison between effects of inclined and vertical cutoff walls on (a) Uplift force, (b) Seepage discharge, (c) Exit gradient

3.6. The combined effects of blanket and cutoff walls on seepage flow, exit gradient, and uplift force

To verify the combined effects of blanket and cutoff walls on seepage flow, exit gradient, and uplift force, blankets and cutoff walls with the lengths of 5, 10, 15, 20 and 30 cm are selected. The upstream head has been held constant ($h=10$ cm) for all cases. Firstly, for cases when there is only a blanket or a cutoff wall with a specific length or depth, uplift pressure distribution is measured from piezometric data, and seepage flow per unit width and exit gradient have been estimated using the software. In Fig. 12-a, the effects of blankets and cutoff walls on uplift force is shown.

Fig. 12-a, shows that the presence of blanket or upstream cutoff wall results in a reduction of uplift force. However, upstream cutoff wall affect uplift force more than upstream blanket and the presence of cutoff wall at downstream end results in increasing uplift force. Note that the middle cutoff walls have not a significant effect on uplift force, even their depths have been increased significantly.

In Fig. 12-b the effects of the measures on reducing

exit gradient are shown. As shown in Fig. 12-b, presence of blanket at upstream end and cutoff wall at downstream end results in a reduction of exit gradient. Also, a downstream cutoff wall affects exit gradient more than upstream blanket. Moreover, Fig. 12-b shows that the effect of an upstream cutoff wall on reducing or increasing exit gradient, also depends on the depth of cutoff wall.

Finally, Fig. 12-c shows that the presence of blanket and cutoff wall results in reducing seepage flow. However, for a specific length of blanket, cutoff wall at downstream end has more effects, on the reduction of seepage flow, than cutoff walls positioned at the middle and upstream end.

Fig. 12 shows that the upstream blanket reduces the amount of uplift force, exit gradient, and seepage flow, simultaneously. Also, in Fig. 12-d the effects of increasing the length of blanket on the rate of reduction in the amount of seepage discharge, uplift force and exit gradient are shown. Fig. 12-d shows that by increasing the length of the blanket up to 30 percent of the whole area of the upstream reservoir, there are 4, 9.6 and 12 percent reduction of the amount of exit gradient, seepage flow, and uplift force, respectively.

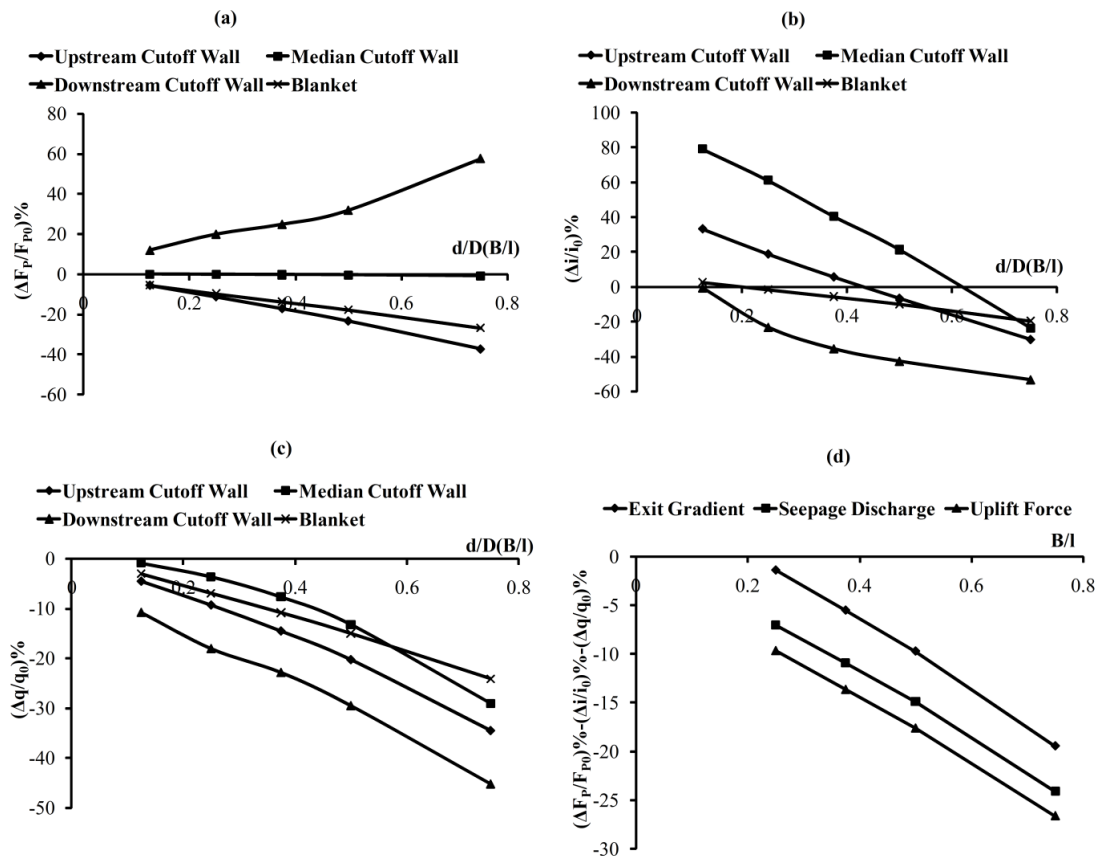

Fig. 12 (a) Comparison between effects of blanket and cutoff wall on uplift force, (b) Comparison between effects of blanket and cutoff wall on exit gradient, (c) Comparison between effects of blanket and cutoff wall on seepage discharge, (d) Comparison between effects of blanket on uplift force, seepage discharge and exit gradient

3.7. The effect of drain position on exit gradient and uplift force

In this section, the variation in uplift force and exit

gradient affected by the presence of an individual drain with various dimension in different positions is evaluated. In this regard, the dimensions of a dam foundation are simulated in GEOSTUDIO 2007 Software (Fig. 13-a). The

upstream head (h) is considered as 5, 10, 15, 20 and 30 m while the drain diameter (D') is considered as 0.5, 1.0 and 2.0 m. The downstream head is set as zero. For any combination of the upstream head and drain diameter, a drain is positioned at $\frac{x}{b} = -\frac{1}{2}, 0, \frac{1}{3}, \frac{2}{3}, 1, \frac{4}{3}, \frac{5}{3}$ while the depths of the drain are considered as 10, 20 and 30 meters under the dam floor. So, a total of 315 cases were considered and the exit gradient and uplift force were estimated by the software. In Fig. 13-b, an example of flow net in the presence of a drain with a diameter of 2 m which is located 30 m from the upstream end at a depth of 20 m and with an upstream head of 20 m is shown. Moreover, in Figs. 14 and 15, a family of curves to indicate the effects of the position and the drain diameter on uplift force and exit gradient, are shown, respectively. In these figures, D = the thickness of the pervious layer, D' = drain diameter, x = the horizontal distance of drain from upstream end, y = the elevation of drain above the bottom of the pervious layer, h = upstream head, and F_{p0} and i_0 are the amounts of uplift force and exit gradient under the same upstream head but without drain, respectively. From Fig. 14 it can be seen that by moving the drain from the upstream end into the direction of the downstream end, uplift pressure is reduced gradually regardless the depth of the drain. The maximum reduction in uplift force takes place when the drain is positioned at a distance of $1/3 b$ (b = dam width) at the downstream of the upstream end. By moving the drain downstream of this

point, uplift force increasing again. Moreover, for a drain of certain diameter at a certain horizontal location, by moving the drain toward the bottom of the pervious layer, the uplift force is increasing.

Fig. 15 shows that the variation of exit gradient depends on the location of the drain, both in horizontal and vertical positions. The maximum reduction in the amount of exit gradient is found at a distance of $2/3 b$ from upstream end or at the downstream end depending on drain dimension and elevation. Similarly, for a drain of certain diameter located at a certain horizontal distance, by moving the drain toward the bottom of the pervious layer, exit gradient is increasing.

Using results obtained from the software, the maximum reduction in the amount of uplift force due to the presence of a drain in a distance of $1/3 b$ from upstream end ($(\Delta F_p)_{\max}$), can be estimated from following equation:

$$\frac{(\Delta F_p)_{\max}}{F_{p0}} = 0.909 \left(\frac{D'}{D} \right)^{0.120} \left(\frac{y}{D} \right)^{0.268} \quad (10)$$

The above equation is obtained from a regression analysis. The corresponding magnitudes of R^2 (0.95) and MSE (0.0002) in Fig. 16 shows a reasonable agreement between two sets of data from numerical method and Eq. (10).

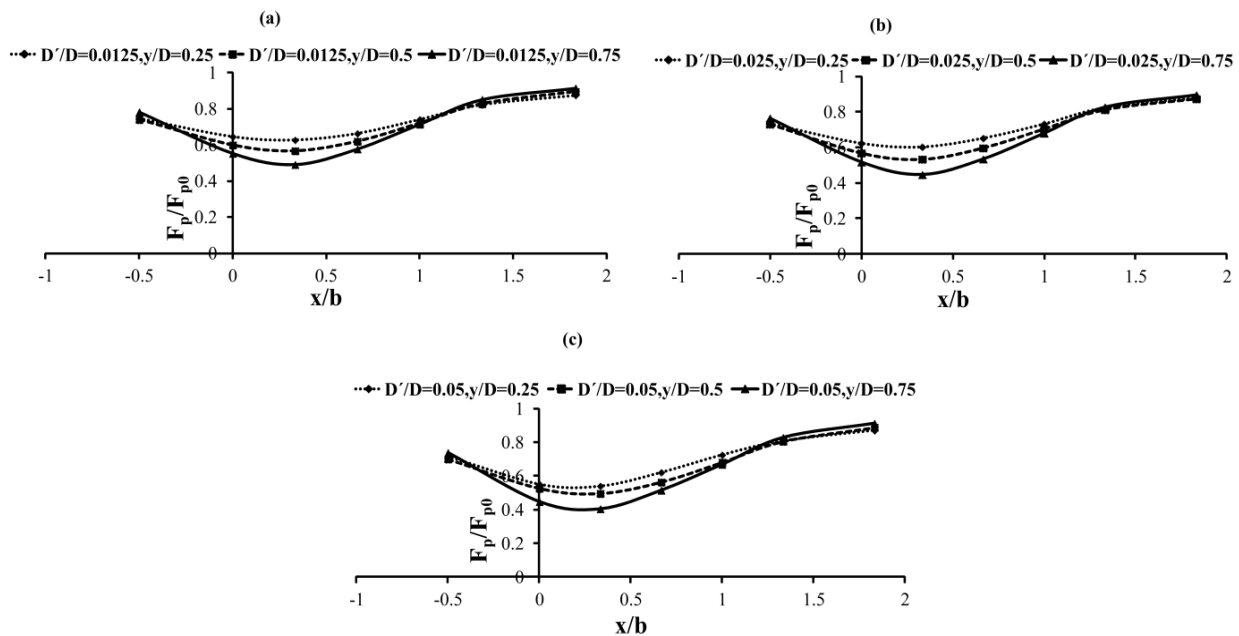

Fig. 14 Effects of the drain position on uplift force ($\frac{H}{D} = 0.5$)

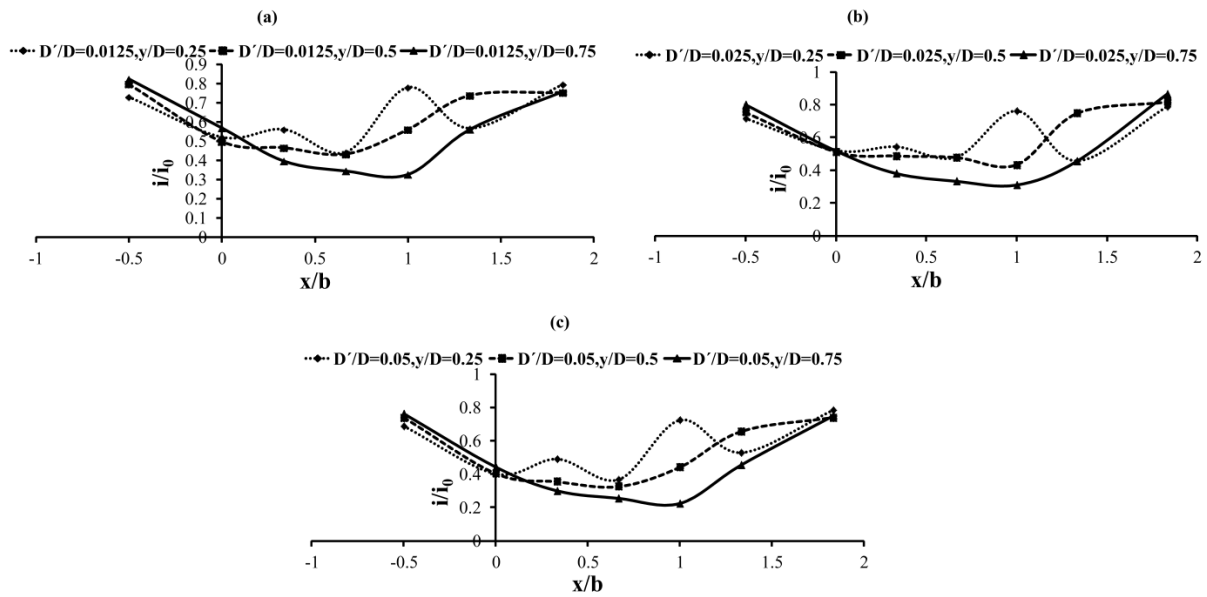

Fig. 15 Effects of the drain position on exit gradient ($\frac{H}{D} = 0.5$)

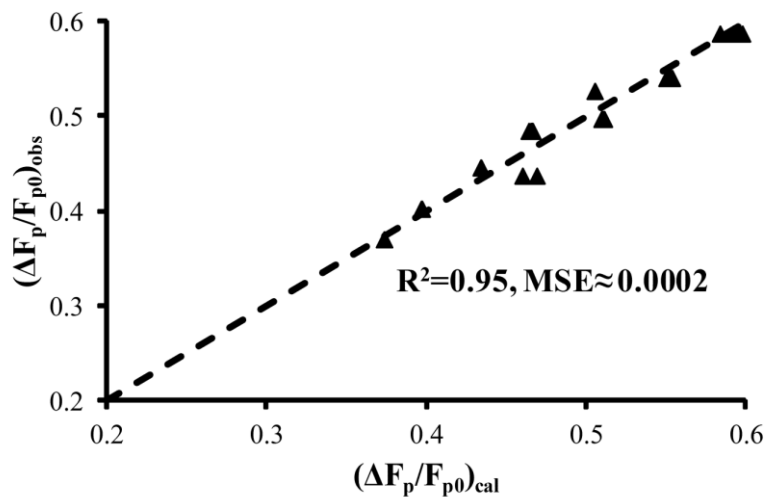

Fig. 16 Comparison between variations of uplift force from Eq. (10) with numerical data in the presence a drain

4. Conclusions

In this paper, the effects of upstream blanket and cutoff walls on reducing seepage flow, exit gradient, and uplift force is investigated using two sets of data obtained from a physical model in a laboratory and from GEOSTUDIO 2007 Software. It is found that the software can be used as a useful tool on estimating the amount of seepage flow, exit gradient, and uplift force for a wide range of conditions. Using data provided from laboratory experiments, it is observed that the best position of cutoff wall to reduce seepage flow is at the downstream end. Moreover, two empirical equations; i.e. Equations (5) and (6), were introduced based on a regression analysis of the model output to estimate the basic and the reduced seepage flow due to installation of cutoff walls.

It is also found that the best position of cutoff wall to reduce the amount of uplift force is at the upstream end.

Unlike our findings, Harr [4]'s method does not distinguish between the impacts of cutoff walls that are located at some distance from the left or the right end of the dam. The discrepancy between the present study and Harr [4] is maximum when the cutoff wall is located at the downstream end.

The effects of inclined cutoff wall on seepage flow, exit gradient and uplift force were evaluated using the software. It is found that the optimum inclined angle depends on the position and the length of cutoff wall. Furthermore, it is observed that the effect of a cutoff wall, installed at the downstream end, on reducing exit gradient is more than an upstream blanket.

Finally, it is concluded that by moving the drain from the upstream end into the direction of the downstream end, uplift pressure is reduced gradually regardless the depth of drain. An approximate equation; i.e. Equation (10), was introduced to estimate the maximum reduction of uplift force as a function of drain diameter and depth.

Despite the progress made in this research, however, there are limitations on using the results for general applications so further researches are needed. For example, Equations (5) and (6) are limited to use when $0.0625 \leq d/D \leq 0.75$ and $0 \leq x/b \leq 1$ and. Also due to narrow width of the flume, the side effects of the flume walls may affect the flow regime passing through porous media. Finally, only one type of soil material was selected as porous media under the structures while a wide range of materials may be available at prototype situations.

Notation

b	Dam width (m)
B	Length of upstream blanket (m)
D_{50}	Mean diameter (m)
d	Length of cutoff wall (m)
D	Depth of impervious layer (m)
F_p	Uplift force (N)
F_{p0}	Uplift force in the absence of cutoff wall, blanket or drain (N)
$F_p\left(\theta_0=\frac{\pi}{2}\right)$	Uplift force at the presence a vertical cutoff wall (N)
h	Upstream head or difference between upstream and downstream heads (m)
$h_{(x,y,t)}$	Total head in any point (m)
i	Available gradient
i_0	Exit gradient in the absence of cutoff wall, blanket or drain
$i\left(\theta_0=\frac{\pi}{2}\right)$	Exit gradient at the presence a vertical cutoff wall
k_x	Horizontal hydraulic conductivity (m/s)
k_y	Vertically hydraulic conductivity (m/s)
L	Downstream permeable length (m)
l	Length of upstream reservoir (m)
Q	Produced discharge rate per unit area of the element (m^3/s)
q	Seepage discharge per unit width (m^2/s)
q_0	Seepage discharge per unit width in the absence of cutoff wall, blanket or drain (m^2/s)
$q\left(\theta_0=\frac{\pi}{2}\right)$	Seepage discharge per unit width at the presence a vertical cutoff wall (m^2/s)
t	Time (s)
x	Distance of cutoff wall or drain from upstream of floor (m)
y	Elevation of drain above the bottom of the pervious layer (m)
D'	Drain diameter (m)
MSE	Mean Standard Error
R^2	Correlation coefficient
θ	Inclined angle (deg)

θ_v Volumetric water content

ΔF_p Variation of uplift force in the presence of inclined cutoff wall (Fig. 11), in the presence cutoff wall or blanket (Fig. 12) (N)

$(\Delta F_p)_{max}$ Maximum reduction in the amount of uplift force due to the presence of a drain in a distance of 1/3 b from upstream end (N)

Δq Variation of unit seepage discharge in the presence of inclined cutoff wall (Fig. 11), in the presence cutoff wall or blanket (Fig. 12) (m^2/s)

Δi Variation of exit gradient in the presence of inclined cutoff wall (Fig. 11), in the presence cutoff wall or blanket (Fig. 12)

References

- [1] Bligh WG. Dams barrages and weirs on porous foundations, Engineering News, 1910, Vol. 64, 708.
- [2] Lane EW. Security from under seepage: Masonry Dams on Earth Foundations, Trans, ASCE, 1935, pp. 1235-1272.
- [3] Khosla AN, Bose NK, McKenzie ET. Design of weirs on pervious foundations, Publication number 12 of the Central Board of Irrigation, Simla, India, 1936.
- [4] Harr ME. Groundwater and Seepage, McGraw-Hill, New York, 1962.
- [5] Pavlovsky NN. The theory of ground water flow beneath hydrotechnical structures, Research Melioration Institute, Petrograd, USSR, 1922 (in Russian).
- [6] Pavlovsky NN. Collected works, Izd. AN SSSR Moscow - Leningrad, USSR, 1956.
- [7] Leliavsky S. Irrigation and hydraulic design, Chapman and Hall, London, 1955.
- [8] Polubarinova-Kochina PY. Theory of groundwater movement, Trans. JM. Roger de Wiest, Princeton University, Princeton, NJ, 1962.
- [9] Fil'chakov PF. The theory of filtration beneath hydrotechnical structures, Vol. 1, Izd-vo Akademii nauk Ukrainskoi SSR, Kiev, 1959.
- [10] Fil'chakov PF. The theory of filtration beneath hydrotechnical structures, Vol. 2, Izd-vo Akademii nauk Ukrainskoi SSR, Kiev, 1960.
- [11] Abedi Koupaei J. Investigation of effective elements on uplift pressure upon diversion dams by using finite difference, thesis for MSC (in Persian), University of Tarbiat Modarres, Tehran, Iran, 1991.
- [12] Griffiths DV, Fenton GA. Three-dimensional seepage through spatially random soil, Journal of Geotechnical and Geoenvironmental Engineering, 1997, Vol. 123, pp. 153-160.
- [13] Opyrchal L. Application of fuzzy sets to identify seepage path through dams, Journal of Hydraulic Engineering, ASCE, 2003, No. 7, Vol. 129, pp. 546-548.
- [14] Sedghi-Asl M, Rahimi H, Khaleghi H. Effect of cutoff wall's depth and situation on reducing seepage under hydraulic structures by using numerical method, 5th Iranian Hydraulic Conference, Iran, 2005 (In persian).
- [15] Rahmani Firoozjaee A, Afshar M. Discrete least square method (DLSM) for the solution of free surface seepage problem. International Journal of Civil Engineering, 2007, No. 2, Vol. 5, pp. 134-143.
- [16] Ahmed AA, Bazaraa AS. Three-dimensional analysis of seepage below and around hydraulic structures, Journal of Hydrologic Engineering, ASCE, 2009, No. 3, Vol. 14, pp. 243-247.

- [17] Ahmed AA. Design of hydraulic structures considering different sheet pile configurations and flow through canal banks, *Computers and Geotechnics*, 2011, No. 4, Vol. 38, pp. 559-565.
- [18] Sedghi-Asl M, Rahimi H, Khaleghi M. Laboratory investigation of the seepage control measures under coastal dikes, *Experimental Techniques*, 2011, No. 1, Vol. 36, pp. 61-71.
- [19] Jain K, Reddi LN. Finite-depth seepage below flat aprons with equal end cutoffs, *Journal of Hydraulic Engineering*, ASCE, 2011, No. 12, Vol. 137, pp. 1659-1667.
- [20] Zainal EAK. The effects of cutoff wall angle on seepage under dams, *Journal of Engineering*, 2011, No. 5, Vol. 17, pp. 1109-1131.
- [21] Jafarih A, Ghannad M. The Effect of Foundation uplift on Elastic Response of Soil-Structure Systems, *International Journal of Civil Engineering*, 2014, No. 2, Vol. 12, pp. 146-157.
- [22] Heidarzadeh M, Mirghasemi A, Niroomand H. Construction of relief wells under artesian flow conditions at dam toes: engineering experiences from Karkheh earth dam, Iran, *International Journal of Civil Engineering*, 2015, No. 1, Vol. 13, pp. 73-80.
- [23] Zienkiewicz OC. *The Finite Element Method*, McGraw-Hill, New York, 1977.
- [24] Krahn J. *Seepage modeling with Seep/w*, An Engineering Methodology, Calagary, Alberta, Canada, 2007.