

Small-Scale Model Test and Three-Dimensional Analysis of Pile-Raft Foundation on Medium-Dense Sand

M. H. Baziar^{1,*}, A. Ghorbani², R. Katzenbach³

Received: December 2007

Revised: July 2008

Accepted: April 2009

Abstract: *The pile-raft foundation is a combination of a raft foundation with piles. Pile-raft foundation has been widely designed, assuming all structure loads to be transferred to piles without considering contribution of the load taken by contact surface between raft and soil. Methods of analysis currently used in practice are based upon relatively conservative assumptions of soil behavior or on the less realistic soil-structure interaction. In this study the bearing -settlement behavior of combined pile-raft foundations on medium dense sand was investigated. 1g physical model test was performed on a circular rigid raft underpinned with four model piles. Numerical simulation was also carried out on the model test, using FLAC-3D, to show compatibility of the numerical analysis with the test. The obtained results showed very good accuracy of the numerical method used in this study as long as the applied load does not exceed the working load, while the performance of numerical model was relatively good for the loads beyond working load.*

Keywords: *pile-raft foundation, 1g physical model test, numerical modeling*

1. Introduction

During the past decade some high-rise and heavy buildings around the world, founded on pile raft system, have been monitored and their settlements were measured and reported by several researchers. Recently, Poulos and David [1] reported a case study, the twin tower in Dubai, in which a disagreement between measured settlements and predicted settlements calculated by boundary element method, were observed.

Considering this problem, it seems the best way to certify about the accuracy of an analysis method of pile-raft foundation is to perform a physical model test according to real conditions of soil in project site. Some few physical model tests have been performed before by researchers. Because the pile-raft foundations rested on very stiff clay is particularly suitable for high-rise building, Thaher and Jesberger [2] investigated the behavior of a vertically loaded pile-raft

foundation, using fully rigid raft, on over-consolidated saturated clay by centrifuge modeling. On the other hand, Horikoshi and Randolph [3] carried out a centrifuge physical model test of pile-raft foundation by a fully flexible raft on stiff clay.

The analysis of pile-raft foundation is a very complex subject due to many factors affecting the behavior of this type of foundation. A number of researchers made efforts to find suitable analysis methods, but regarding to complexity involved in pile-raft analysis the researchers had to make some limitations in the analyses. Poulos and Davis [4], and Randolph [5] proposed a simplified analytical method named PDR with the assumptions of rigid cap and linear behavior of soil. Many researchers [6-10] used three-dimensional finite elements methods to model real behavior of pile-raft foundations. In these methods, there were also some restrictions to model real section, i.e. circular or pipe sections, and real contact behavior between piles and soil.

In the scope of this research, a new physical model test of pile-raft foundation is performed. The soil used in the present test is a medium relative density sand that is different with what other researchers have used before in their physical model tests. This study presents the

* Corresponding Author: Email: baziar@iust.ac.ir

1 Professor, School of Civil Engineering, Iran University of Science and Technology

2 Assistant Professor, Faculty of Civil Engineering, Guilan University

3 Professor, Institute and Laboratory of Geotechnics, Technical University of Darmstadt, Germany

results of three-dimensional non-linear analysis of piled raft foundations loaded until failure, and for this reason the applied load in the physical model test is increased up to two times of ultimate load capacity of model obtained by conventional methods.

2. Physical model test

In this study 1g physical model test was performed to investigate the bearing behavior of pile-raft foundation in medium sand. The schematic shape of pile-raft model, used in 1g test, is shown in Figure 1. The model of pile-raft was made by four piles installed beneath a rigid raft. The container adopted for testing the model was a cylindrical steel tube with internal diameter of 1000 mm, height of 1000 mm and a wall thickness of 10 mm.

The raft model was a rigid steel cylinder with 220 mm in diameter and 40mm in thickness. To measure the settlements of the raft, three linear vertical displacement transducers (LVDT) were

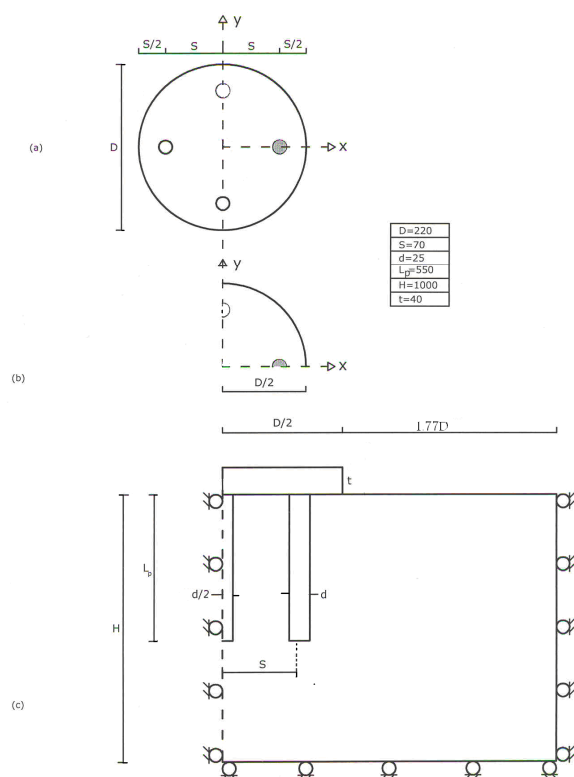

Fig. 1. a) 1g Physical model geometry, b) axi-symmetric numerical simulation with one quarter of model, c) boundary conditions of numerical simulation

installed at three points on the corners of raft with high precision of 0.003 mm. The settlement of the raft was calculated from the average values recorded at three transducers in order to neglect the effect of possible tilting.

The piles in the model were constructed of steel rods with 25 mm diameter and 550 mm length. One pile was instrumented with strain gauges located at the pile top, just below the cap, to measure the load transmitted from the raft to the piles.

The soil profile consisted of dry sand with mean grain size of 0.35 mm, a uniformity coefficient of 3.0 and a specific gravity of 2.65. The maximum and minimum void ratios of soil were 0.78 and 0.45 respectively. To fill the container, the sand was rained into the container by means of sand depositing apparatus. The average density of the poured sand was about 1.60 gr/cm³ and the relative density of soil was obtained to be about 45 percent representing medium sand [11].

The ultimate load capacity of the pile-raft model using conventional methods, i.e. equations of Vesic [12] and Coyle and Castello [13], proposed by Poulos [14] was calculated to be about 8.0 kN. The vertical load was applied in a stepwise manner by a hydraulic system and a load cell was mounted on the loading piston to measure the total vertical imposed load. The maximum applied load was about 15 kN equal to two times of ultimate load.

Laboratory tests were performed to measure the geotechnical parameters of medium sand used in physical model test. Based on the results obtained from these tests, the internal friction (ϕ), the cohesion coefficient (C), the poisson's ratio (ν_s) and the average elastic modulus (E_s) were obtained to be 38 degree, 0.01 KPa, 0.25 and 12.5 MPa respectively.

3. Nonlinear three- dimensional numerical analysis

The FLAC-3D software was used to investigate a suitable analysis approach based on finite difference method. In order to set up the numerical model and to carry on a simulation, three fundamental components of finite difference

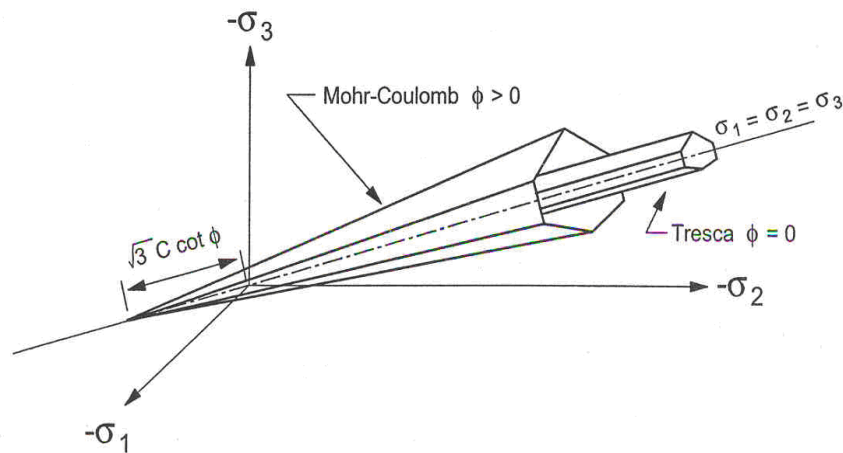

Fig. 2. Mohr – Coulomb constitutive model used in present study to model nonlinear behavior of medium dense sand

approach including grid geometry, boundary and initial condition and constitutive behavior should be specified.

The grid can be defined from the geometry of model as shown in Figure 1. Solid elements were used to define geometry of soil, piles and raft. The procedure of geometric modeling was simplified using pre-shapes zones. Solid zones were divided easily to many elements to generate grid or mesh. The real circular pile was modeled, while in most previous studies [10] because of difficulties to model circular pile it was replaced with an equivalent square pile. Due to axis-symmetry of the problem, only one quarter of the pile-raft was modeled. The boundary conditions applied to numerical models were

schematically shown in Figure1. The displacements of the symmetry boundaries at $x=0$ and $y=0$ were zero in the x - and y - directions respectively. To simulate these conditions, roller boundaries were set along symmetry planes. Outsides and bottom planes of the numerical models were also constrained using roller boundaries to provide the stability conditions.

In most recently advanced numerical simulation of pile-raft, [10], a complex constitutive model like cap model was used to present non-linearity of soil. Complex constitutive models need extra soil parameter than simple constitutive models (i.e. Mohr-Coulomb) to define in numerical simulation. Therefore, to use a complex constitutive model

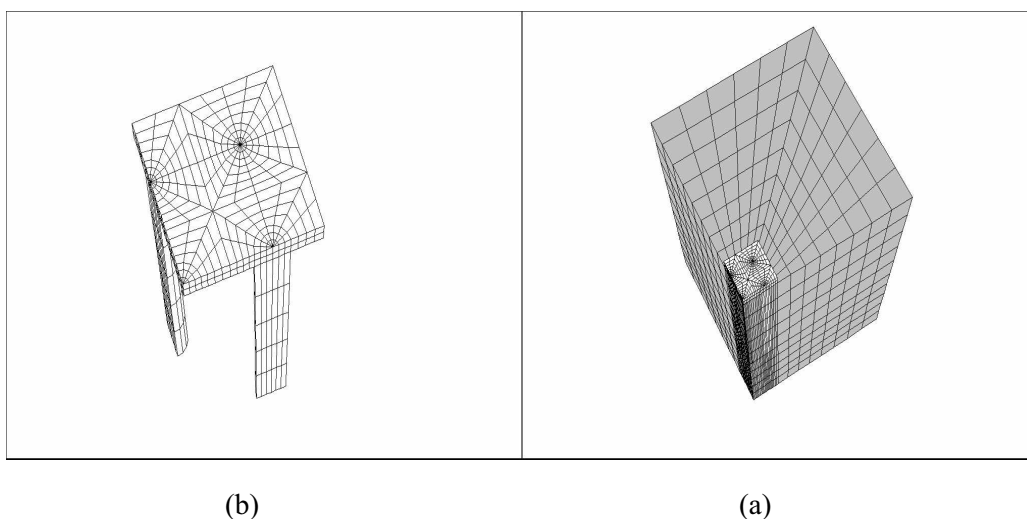

Fig. 3. Numerical model of pile-raft foundation under 1g physical test using FLAC-3D
a) Total mesh b) pile raft mesh

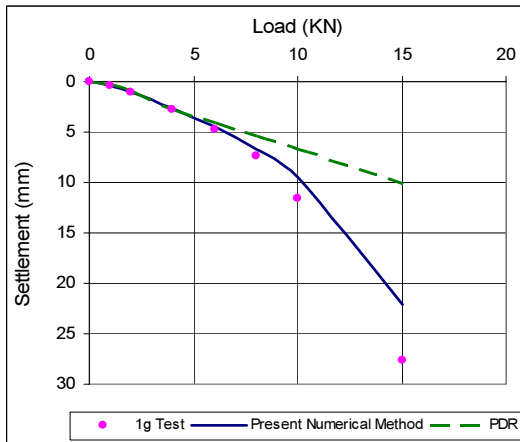

Fig. 4. Measured and computed settlements of pile-raft foundation under 1g physical model test on medium dense sand

needs many efforts, such as performing complex shear tests or back analyses, to specify soil parameters. In the present research a simple constitutive model, Mohr-Coulomb elasto-plastic criteria, as shown in Figure 2 was used for the medium sandy soil to overcome the mentioned difficulties. The main soil parameters used in the analysis are internal friction angle (ϕ), cohesion coefficient (C), Young modulus (E_s) and Poisson's ratio (ν_s). Using Mohr-Coulomb model may also reduce the time of the analysis in comparison with previous approaches having complex constitutive models.

One of the main problems in numerical simulation of pile-raft is to model the contact between soil and foundation including piles and raft. Since sliding is possible to occur on the contact zone, to present the real condition, it is needed to implement interface elements on the contact zone. In present study, the real contact between soil sub-grid and structural sub-grid were modeled using rough interface elements.

Before applying the load to the system, the model equilibrium under initial state was controlled. To simulate this condition, the model was simulated under initial stresses caused by gravity of soil only using FLAC-3D software.

4. Results and Discussions

The numerical model mesh for piled raft and its surrounded soil in simulation of 1g physical test is shown in Figure 3. The total computed

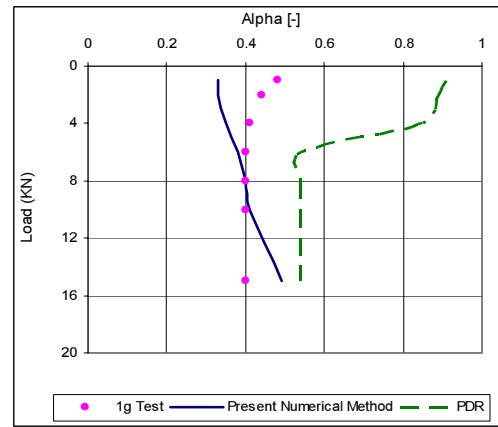

Fig. 5. The variations of the measured and computed α_{pr} versus total load of pile-raft foundation under 1g physical model test on medium dense sand

settlement obtained from present approach is compared with the measured settlement in Figure 4. It can be seen that the general trend of settlement obtained by the present numerical method shows good agreement with the measured settlement. The calculated and measured settlements under the design load were 2.7 mm and 2.8 mm respectively indicating that the present method predicts the settlement very well and with only about 4 percent errors. For the applied load of 15 KN, equal to two times of the ultimate load, the measured settlement was about 27.6 mm, while the calculated settlement was about 22.1 mm respectively indicating the present method underestimates the settlement by about 20 percent. Therefore, the present method has shown a negligible error up to working load and also acceptable accuracy in nonlinear zone.

The coefficient of " α_{pr} " is defined by the ratio of load carried by pile group to total applied load, so we can determine the contribution of raft to carry applied loads transferred from superstructure. The determination of " α_{pr} " is very important in order to optimize the design of pile-raft system. Because of calculation " α_{pr} " is complex, conventional methods ignore any contribution of raft to carry load that means the " α_{pr} " equal zero. On the other hand, in most cases, even medium clay soils, [3] showed raft has an important role to carry loads meaning " α_{pr} " is greater zero. The variation of the measured and computed coefficient of α_{pr} versus the total load is shown in Figure 5. As shown a

good agreement between the predicted and measured α_{pr} was achieved. The computed results gave of $\alpha_{pr} = 0.35$ under the design load, while the measured value was about 0.41. The computed and measured value of α_{pr} versus ultimate load was the same and near to 40 percent. It is noticeable that coefficient (α_{pr}) remains nearby constant about 0.4 after the settlement exceeds to 20 percent of pile diameter indicating full mobilization of piles capacity.

The Poulos-Davis and Randolph method [1,5], named PDR method, was also used to analyze the present case study. The comparison between settlements obtained by the present numerical method and the PDR method are shown in Figure 4. The PDR method as well as the present numerical method showed good agreement in linear zone up to working load. For the load passing the working load, in which the bearing behavior of pile-raft foundation is mostly nonlinear, the load-settlement predicted by PDR method remained approximately linear. The maximum error of PDR method was about 63 percent under two times of ultimate load. The coefficients of α_{pr} obtained from PDR method and present numerical method is compared in Figure 5. The errors of PDR method and present numerical method were about 100% and 15% respectively under working load. The amount of errors was also about zero for present method and about 35% for PDR method under ultimate load.

5. Conclusions

In the present research the bearing behavior of pile-raft foundation has been studied using physical and numerical modeling.

A new physical model test has been performed to study the bearing behavior of a rigid pile-raft foundation on medium sandy soil. The pile-raft model loaded up to 2 times of the ultimate load, calculating by conventional bearing capacity methods, to investigate the accuracy of various methods to predict nonlinear behavior of pile-raft foundation.

The calculated results from the Poulos-Davis and Randolph method named PDR method as well as present approach showed good agreement with the results of physical model test for the load

up to the working load. The PDR method showed approximately linear behavior for loads exceeding the working load. On the other hand, the present approach showed a nonlinear behavior for the loads more than the working load. The obtained results indicated a better performance of the present approach comparing to PDR method to predict real bearing behavior of pile-raft foundation on medium sandy soils for loads higher than the working load.

References:

- [1] Poulos, H.G. and Davis, E.H. (1980) "Pile Foundation Analysis and Design" Wiley, New York.
- [2] Thaher, M. H.G. and Jessberger (1991) "Investigation of the behavior of pile-raft foundation by centrifuge modeling" Proc. 10th European Conf. of Soil Mech. Foundation Eng., Florence, Vol. 1, PP. 597- 603
- [3] Horikoshi, K. and Randolph, M.F. (1994) "Settlement of piled raft foundations on clay" Centrifuge94, Balkema, Rotterdam, pp. 449-454
- [4] Poulos, H.G. and David, A.J. (2005) "Foundation Design for the Emirates twin tower .", Dubai, Journal of Geotechnical , Vol. 6, No. 42, PP. 716-730
- [5] Randolph, M.F. (1994) "Design Methods for Pile Groups and Pile Rafts." S.O.A. Report, 13 ICSMFE, New Delhi, 5: 61-82.
- [6] Zhang, G.M., Lee, I.K. and Zhao, X.H. (1991) "Interactive Analysis of Behavior of Ra ft- Pile Foundations." Proc. Geo-Coast'91
- [7] Lee, I.K., (1993) "Analysis and performance of raft and raft-pile foundation in a homogeneous soil", Proc. 3rd Int. Conf. Case His. In Geotech. Engng. St. Louis (also research reported R133, ADFA, University of New South Wales, Australia.
- [8] Baziar M. H., Ghorbani,A. and Ghiassian , H. (1999) , "Finite Element and Simplified

- Analysis of Piled- Raft System.”, Proceeding of 4th International Conference on Deep Foundation Practice in Cooperating Pile Talk, Singapore, pp. 125-133, July 29-30
- [9] Baziar M. H., and Ghorbani, A. (1999) , “Linear and Non linear Analysis of Piled- Raft Foundation and Comparison With Other Methods.”, International Journal of Engineering Science, in Persian, IUST, Tehran, Iran, Vol. 10, pp. 93-109
- [10] Reul, O. and Randolph, M.F. (2003) “ A contribution to design strategies for piled raft to nonuniform vertical loading ”, Journal of Geotechnical and Geoenvironmental Engineering, ASCE, No. 130, Vol.130,pp. 47-58
- [11] Bowles, E., (1982) “ Foundation analysis and design”, McGraw-Hill Book Company.
- [12] Vesic, A. S.(1973), “Analysis of ultimate loads of shallow Foundation”, Journal of the Soil Mechanics and Foundation Division, ASCE, Vol. 99, No. SM1, pp. 45-73
- [13] Coyle, H. M. ; and Castello, R. R. (1981). “New Design Correlations for Piles in Sand” , Journal of the Soil Mechanics and Foundation Division ,ASCE, Vol. 107, No. GT7, pp. 965-986
- [14] Poulos, H.G (2001) “ Piled Raft Foundation: Design and Applications”, Geotechnique, Vol. 51, No. 2, PP. 95-113