

Diagonal Compression Criterion on Compression Reinforcement Ratio in Flexural HSRC Members

A.A. Maghsoudi¹, H. Akbarzadeh Bengar²

¹Assistant Professor, Department of Civil Engineering at Kerman University, Kerman, Iran.
maghsoudi.a.a@mail.uk.ac.ir

²PhD. Candidate (Academic Member of Shomal University of Iran),
Department of Civil Engineering at Kerman University, Kerman, Iran.
h_akbarzadeh_b@yahoo.com

Abstract: Limit to the tension reinforcement ratio (ρ) in flexural high strength reinforced concrete (HSRC) members is based on the requirement that tension failure as sufficient rotation capacity are ensured at ultimate limit state. However, the provisions for the total amount of longitudinal reinforcement ratio (ρ and ρ') are not associated with any rational derivation. In this paper, a quantitative measure to evaluate an upper limit to the compression reinforcement ratio ρ'_{max} of flexural HSRC members is proposed. The quantitative criterion to ρ'_{max} can be derived from i) steel congestion and ii) considerations that are related to the diagonal compression bearing capacity of the members.

In this paper it is shown that, when shear loading is dominant, the limit to ρ' is set by the diagonal compression criterion. Parameters that affect this limit are deeply investigated and the expressions were derived for different end conditions, to provide an additional tool for a better design and assessment of the flexural capacity of HSRC members.

Keywords: Congestion Criterion, Diagonal Compression, HSRC, Upper Limit to ρ' , End conditions.

1. Introduction

RC and HSRC design codes set an upper limit to the bending resistance of flexural members with only tension reinforcement (considered here as $M_{cd,max}$). The limit is set in order to ensure tension failure as well as sufficient rotational capacity at ultimate limit state, either by maximum permissible tension reinforcement ratio [1] or by a maximum depth of the concrete compression area [2, 3]. It is also possible an additional resistance moment ΔM added to the resistance moment $M_{cd,max}$ by adding compression reinforcement and an additional amount of tension reinforcement for equilibrium. Thus, while the upper limit to the tension reinforcement ratio is derived from the “proficient-design” considerations described above, the limitation on the total amount of

longitudinal reinforcement ratio (and, therefore, on the compression reinforcement ratio) in flexural RC and HSRC members is not associated with any rational derivation.

Lin and Furlong [4] proposed rational derivations for longitudinal steel limits of RC columns. Dancygier and Eid [5] proposed an upper limit to the amount of longitudinal compression reinforcement in flexural RC simply supported beams. No report was observed for an upper limit to compression reinforcement ratio in flexural HSRC members. The authors proposed an upper limit to compression reinforcement ratio in HSRC flexural element, based on the congestion criterion for different end conditions [6, 7]. This paper proposes an upper limit to the amount of longitudinal compression reinforcement in flexural HSRC

members of both simply and continuous supports based on the another criterion which is associated with the prevention of diagonal compression failure due to shear loading (As this criterion is depended on some of the congestion criterion, therefore they are very briefly repeated here [6]). For a better understanding, some work examples are solved and presented in appendix.

2. Maximum Steel Ratio Based on Congestion for HSRC Members [7]

As stated, for RC columns and flexural elements [4, 5], perhaps the most obvious reason for an upper limit to compression reinforcement in flexural members is the congestion of space if too many bars are used. An upper limit to the number of tension and compression bars in HSRC rectangular members is attained when they are placed respectively, in a maximum number of rows, n and n' (Fig.1). The maximum numbers, m and m' , of tension and compression bars that can be placed per row are given by

$$m = \text{ROUND DOWN} \left(\frac{b - 2C_1 + S_h}{S_h + \phi} \right) \quad (1a)$$

$$m' = \text{ROUND DOWN} \left(\frac{b - 2C_1 + S_h}{S_h + \phi'} \right) \quad (1b)$$

Where ϕ and ϕ' are the tension and compression bar diameters, respectively.

To determine the maximum total number of longitudinal compression bars based on geometrical construction limitations on placement and spacing of the reinforcing steel eqn. (1) as well as the following further requirements:
Equilibrium, which for rectangular cross sections is giving by

$$\rho = \rho' + \frac{\beta_1 y}{d} \alpha \frac{f'_c}{f_y} \quad (2)$$

Where ρ' and ρ are the tension and compression reinforcement ratios, respectively; f'_c is the characteristic cylinder compressive strength of concrete; f_y is the reinforcement steel yield stress; y is the height of the concrete compression area; β_1 is the ratio between the height of the stress block and y ; α is the stress block coefficient.

Tension failure mode (i.e., at ultimate limit state ULS the tension reinforcement strain ε_s has reached its yield strain ε_y , also for an efficient design, $\varepsilon'_{s \min} \geq \varepsilon_y$).

$$\varepsilon'_{s \min} = \frac{\varepsilon_{cu}}{y} \{ h - y - c_1 - n(\phi + s_v) - 0.5\phi \} \geq \varepsilon_y \quad (3)$$

$$\varepsilon'_{s \min} = \frac{\varepsilon_{cu}}{y} \{ h - y - c_1 - n'(\phi' + s_v) - 0.5\phi' \} \geq \varepsilon_y \quad (4)$$

ε_{cu} is the ultimate concrete strain; and ε_y is the reinforcement yield strain.

Proficient design requires sufficient rotation capacity at the ultimate limit state [1-3]. The requirement for sufficient rotation capacity is set by a provision to the concrete compression area acted by an equivalent stress block A'_c [2]. For rectangular cross section $A'_{c, \max}$ can be written as follows:

$$A'_{c, \max} = \beta_3 \cdot b \cdot d \quad (5)$$

For rectangular cross sections with HSC based on ACI, β_3 is given by

$$\beta_3 = 0.75 \beta_1 \left(\frac{\varepsilon_{cu}}{\varepsilon_{cu} + \varepsilon_y} \right) \quad (6)$$

Assuming linear strain distribution along the cross section's height (Fig. 1):

$$y \leq y_{\max} = \frac{\beta_3}{\beta_1} d \quad (7)$$

A solution to eqn. (2) and to the geometric conditions in eqn. (1) is sought, subject to the constraints in eqn. (3), (4) and (7). The maximum reinforcement ratios that comply

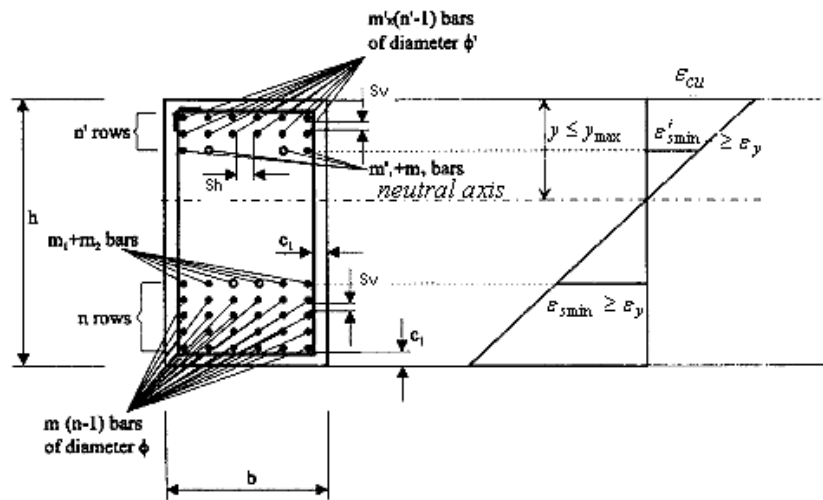

Fig.1. sagging (positive) moment section.

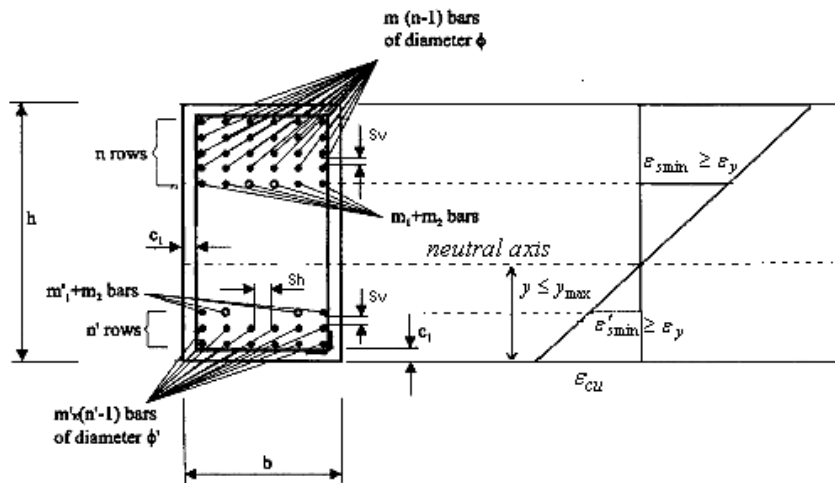

Fig.1. hogging (negative) moment section.

with construction and with proficient-design requirements are given by

$$m_2 = \min(m - m_1; m' - m'_1) \geq 0 \quad (8)$$

$$\rho_{max} = \frac{[(n-1)m + m_1 + m_2] \pi \phi^2}{4bd} \quad (9a)$$

$$\rho_{max} = \frac{[(n-1)m + m_1 + m_2] \pi \phi^2}{4bd} \quad (9b)$$

$$d = h - c_1 - 0.5\phi$$

$$\frac{[\frac{1}{2}(\phi + S_v)(n-2)(n-1)m] + [(m_1 + m_2)(n-1)(\phi + S_v)]}{m(n-1) + m_1 + m_2} \quad (10)$$

3. Maximum Steel Ratio Based on Diagonal Compression of HSC

The load-bearing capacity of a beam with relatively heavy longitudinal reinforcement and with adequate shear reinforcement would still be limited by the diagonal compression failure of the concrete. Thus, another criterion for an upper limit to the longitudinal compression reinforcement ratio in HSC can be set. For engineering design purposes this limit can be determined based on the truss analogy from the requirement that the compression stress in an inclined concrete

strut does not exceed its strength $v_o f'_c$ [8].

$$\sigma_c = \frac{\tau_v}{\sin \theta \cos \theta + \sin^2 \theta \cot \alpha} \leq v_o f'_c \quad (11)$$

Where τ_v is the shear stress resisted by the shear reinforcement; θ and α are the inclinations of the concrete strut and have the shear-reinforcement tie, respectively; and v_o is the non dimensional reduction factor. Where $v_o f'_c$ is the effective compressive strength and its values for HSC are selected from MC90 [9] as follows

$$v_o f'_c = 1.7 f_c^{0.667} \quad (12)$$

Where,

$$v_o = 1.7 f_c^{(-1/3)} \quad (13)$$

The design shear stress τ_d , which is caused by the design shear force V_d , is obtained by

$$\tau_d = \frac{V_d}{b_w Z} = \tau_v + \tau_{dc} \quad (14)$$

Where τ_{dc} is the shear resistance attributed to the concrete (material adhesion, friction along the shear cracks, and the longitudinal reinforcement's dowel action); and b_w is the width of the web. The bending moment M_{cd} is the moment that is resisted by the tension reinforcement and by the concrete without compression reinforcement, and Z is the lever arm between the compression and tension forces and given by

$$Z = \frac{M_{cd}}{A'_c \sigma'_c} \quad (15)$$

An upper limit to this moment $M_{cd,max}$ is set according to the maximum height of the concrete compression area. As long as the design moment M_d is smaller than $M_{cd,max}$, compression reinforcement is not required, and $M_d \equiv M_{cd}$. However, when M_d is larger than $M_{cd,max}$, compression reinforcement may be used to increase the resistance by

ΔM , such that $M_d = M_{cd,max} + \Delta M$. In this case M_{cd} in eqn. (15) are a portion of the design moment M_d and the above definition of Z holds for a constant yield stress, or for a moderate stress variation along the longitudinal compression reinforcement.

The shear stress τ_v , which represents the shear force that is resisted by the shear reinforcement, is equal to the difference between τ_d and τ_{dc} of eqn. (14). Substituting Z from eqn. (15) into eqn. (14) yields

$$\tau_v = \frac{V_d A'_c \sigma'_c}{b_w M_{cd}} - \tau_{dc} \quad (16)$$

The shear force V_d and M_{cd} the moment in eqn. (16) should be the internal force and moment at the same cross section of the beam, respectively. However in the usual design practice Z in eqn. (14) is taken as a constant for each portion of the shear diagram, and it is equal to the internal lever arm corresponding to the maximum design moment M_d (absolute value) in that span of the beam.

The shear stress, which is resisted by the concrete τ_{dc} can be related to the concrete strength by introducing a coefficient, denoted here as β_2 and its value based on (ACI) is given by

$$\tau_{dc} = 0.159 \sqrt{f'_c} + 17.46 \rho_w \frac{V_d d}{M_d} = \beta_2 f'_c \quad (17)$$

Where f'_c is given in MPa; ρ_w is the longitudinal tension reinforcement ratio and d is the effective depth and $\frac{V_d d}{M_d} \leq 1$. Hence, β_2 is given by

$$\beta_2 = 0.159 f_c^{(-1/2)} + 17.46 (\rho_w \beta_v L / d f'_c)^{-1} \quad (18)$$

where L is the span length; β_v is the non dimensional moment-to-shear ratio

$$\beta_v = \frac{M}{V_d L} \quad (19)$$

It is noted that, the value of $\tau_{dc} \leq 0.292\sqrt{f'_c}$.

Eqn. (11) can be written in terms of ΔM and $M_{cd,max}$ by substitution of τ_v, τ_{dc} , and Z , from eqn. (16), eqn. (17), and eqn. (15), respectively, and an upper limit to is obtained with $M_{cd} = M_{cd,max}$, $A'_c = A'_{c,max}$ (substituted from eqn. (5)), and $\theta = 90 - \alpha/2$ [9], which after rearranging terms yields for rectangular cross sections as

$$\left(\frac{\Delta M}{M_{cd,max}}\right)_{max} = \frac{1}{\alpha} \frac{\beta_v L}{\beta_3 d} \left(\beta_2 + \frac{v}{2 \tan \frac{\alpha}{2}} \right) - 1 \quad (20)$$

Note that β_v is also equal to the shear span-to-beam's span ratio.

Now to obtain an expression for an upper limit to ρ' , the moments ΔM and $M_{cd,max}$ are expressed in terms of the reinforcement ratios as follows:

$$\Delta M = \rho' b_w d^2 f_y \left(1 - \frac{d'}{d} \right) \quad (21)$$

$$\begin{aligned} M_{cd,max} &= \alpha f_c A'_{c,max} Z_{min} \\ &= \alpha f'_c \beta_3 b_w d Z_{min} \end{aligned} \quad (22)$$

Where d' is the distance from the extreme compression fiber to the centroid of the compression reinforcement. Substitution ΔM and $M_{cd,max}$ into eqn. (20) yields an upper limit for the compression reinforcement ratio, which is related to the diagonal-compression-strength criterion. With $Z_{min} = (1 - \beta_3/2)d$ in rectangular cross sections this upper limit is given by

$$\rho'_{max} = \frac{f'_c}{f_y} \left(\frac{1 - \beta_3}{2} \right) \left[\frac{\beta_v L}{d} \left(\beta_2 + \frac{v_o}{2 \tan \frac{\alpha}{2}} \right) - \alpha \beta_3 \right] \quad (23)$$

Eqn. (23) shows that the compression reinforcement ratio may be limited not only by construction consideration (congestion of steel). It provides a limitation on ρ' that depends also on the L/d ratio and on the

moment-to-shear loading ratio results or shear span-to-beam's span ratio (the coefficient). This result conforms to the know relation between a resistance to its flexural resistance (or to the effect of the shear span-to-depth ratio a/d (note that $a/d = \beta_v \cdot L/d$)).

The expression for ρ'_{max} in eqn. (23) shows that when bending governs the beam's loading (high β_v), ρ'_{max} is determined by construction aspects (steel congestion of eqn. (9)), which is already proved by the authors and its full report is presented in [7].

A computer program is developed and the effects of various parameters on ρ'_{max} (as demonstrated in the following work example) are taken into considerations for both simply supported (s-s) and Fixed-ended beams, considering hogging and sagging moment.

4. Examples

The effects of various parameters on ρ'_{max} are demonstrated in the example of the simply and a Fixed-ended beam, loaded by concentrated loads of N_p which are equally spaced along the beam's span. The total load on the beam Q is constant and therefore each load is equal to Q/N_p (therefore, $N_p \rightarrow \infty$ for the case of a uniformly distributed load). The effect of the moment-to-shear loading ratio β_v on the maximum compression reinforcement ratio ρ'_{max} is examined through the effect of the loading type (i.e., number of concentrated loads N_p), and of the beam's geometry L/d . Other parameters that affect ρ'_{max} are the concrete and the steel strengths, the bars diameter and the ratio of the height to width of the section.

For the following assumptions considered,

the calculations are done based on the ACI, to find out the ρ'_{max} for HSC; $\varepsilon_{cu}=0.003$, $\alpha=0.85$, $\beta_1=1.09 - 0.008 f'_c$, $0.65 \leq \beta_1 \leq 0.85$. The values of $S_h=S_v=25mm$, if ϕ and ϕ' are less than 25mm, otherwise their values are taken equal to the bar diameter. The c_l , is considered to be 38mm for the case of the concrete subjected to unexposed conditions.

The dependence of the ρ'_{max} on these parameters based on the diagonal compression failure criterion eqn. (23) and on the steel congestion and proficient-design criterion eqn. (9) is described in Figs. 2-4 as follows (whereas, the full report of the steel congestions and proficient-design criterion are given in reference [7]);

4.1 Moment-to-Shear Loading Ratio

The influence of the moment-to-shear loading ratio (or shear span-to-beam span) on ρ'_{max} for $L/d=7, 10$ and 15 , while the number of loads are varying ($N_p=1 \rightarrow \infty$; for Fixed Ended condition; $\beta_v=1/4 \rightarrow 1/6$ and for s-s condition; $\beta_v=1/2 \rightarrow 1/4$) is shown in Fig. 2 (other details of this example are presented in Fig. 2). It can be seen that, the lower the relative shear load (higher β_v , lower N_p , or higher ratio of L/d), the higher value for ρ'_{max} we'll be obtained, which is based on diagonal compression consideration. The influence of the loading type becomes moderate when the total load is distributed over more than 11 concentrated loads ($\sim 1/5.538 \geq \beta_v \geq 1/6$).

It can also be seen in Fig. 2 that the diagonal compression criterion is more dominant when vertical stirrups are used (compared with inclined shear reinforcement; see $\alpha = 45^\circ$ and $\alpha = 90^\circ$ in Fig. 2). The results are also indicating that, for simply supported beams, a higher value of ρ'_{max} we'll be

obtained while compared with the Fixed Ended conditions.

4.2 L/d Ratio

Fig. 2 also shows the dependence of ρ'_{max} , which is set by the diagonal compression criterion of eqn. (23) on the L/d ratio. For vertical stirrups ($\alpha = 90^\circ$), ρ'_{max} is set by diagonal compression for $N_p > 2$ (when $\beta_v > 0.22$ for Fixed ended beams). While for all values of, L/d of s-s beams conditions and for $L/d=10$ and 15 of Fixed Ended conditions for all N_p values, ρ'_{max} is set by the steel congestion criterion eqn. (9).

The maximum compression reinforcement ratio ρ'_{max} is shown in Fig. 3 for L/d ratios that vary from 7 to 18 and for a beam, which is loaded by two equal concentrated or by uniformly distributed loads. The figure shows that for Fixed Ended conditions of uniformly distributed load, at lower L/d ratios the upper limit to ρ' is set by considerations based on diagonal compression eqn. (23).

4.3 Bar Diameter

The influence of the steel bar diameters on the limit of ρ'_{max} are shown in reference [6, 7] according to the steel congestion criterion eqn. (9) and it was shown that, the larger the diameter of the longitudinal bars, the higher ρ'_{max} is required. Whereas, considerations that are based on (Fig.3) diagonal failure eqn. (23) do not depend on the bar diameters. Therefore, The L/d ratios, above which ρ'_{max} is set by eqn. (9), increases as the bar diameters are increased.

As shown in Fig. 3 for Fixed Ended beams when used $\phi = \phi' = 25mm$, and the value of $\beta_v = 1/6$ and $L/d > 9.53$ and also for $\beta_v = 2/9$ and $L/d > 7.148$, the governing equation for

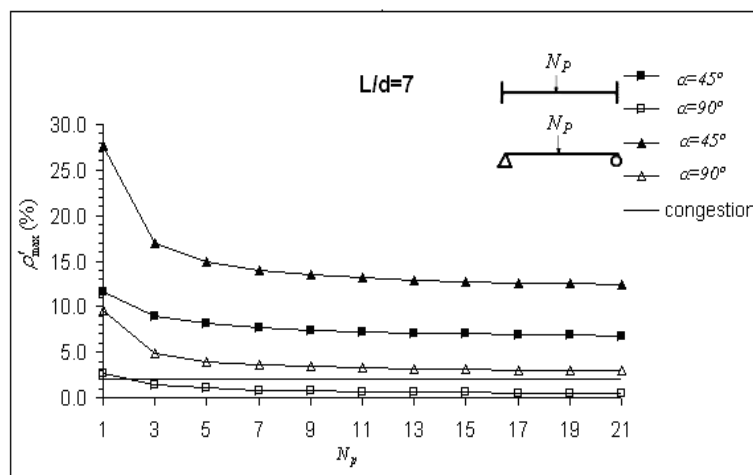
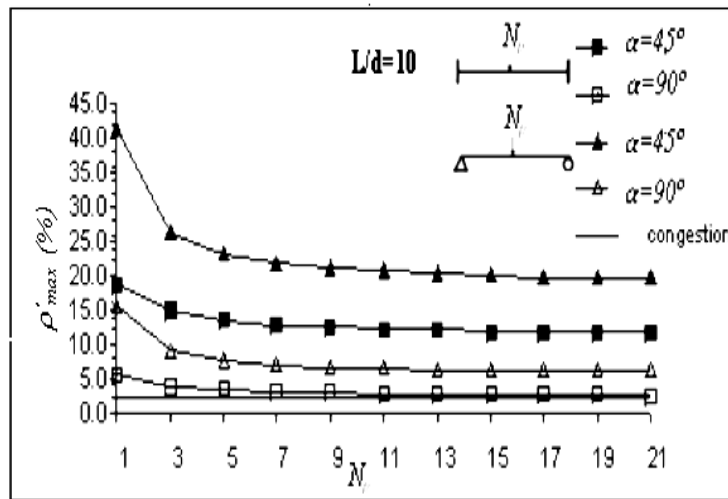
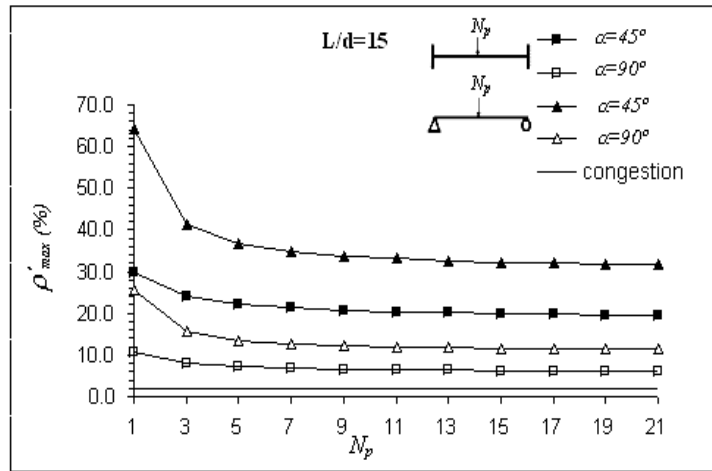

Fig.2. Effect of the bending to the shear loading ratio for s-s and Fixed Ended beams ($h=800\text{mm}$, $b=400\text{mm}$, $f'_c=80\text{MPa}$, $f_y=400\text{MPa}$, $\phi = \phi' = 25\text{mm}$).

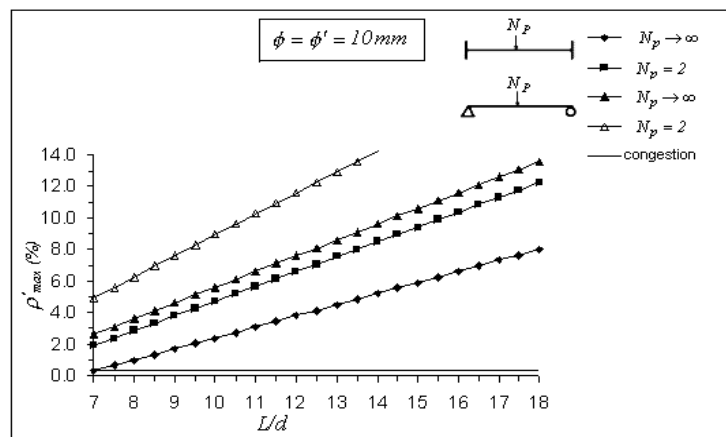
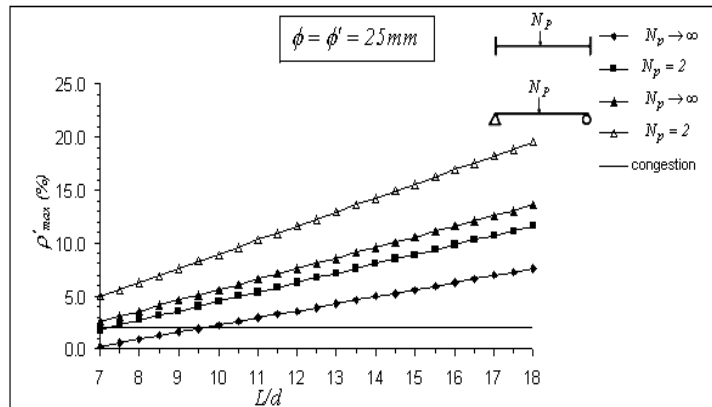

Fig.3. Effect of beam's L/d ratio on ρ'_{max} for Fixed ended beam and simply supported beam loaded with two concentrated loads and with uniformly distributed load ($h=800\text{mm}$, $b=400\text{mm}$, $f'_c=80\text{MPa}$, $f_y=400\text{MPa}$, $\alpha=90^\circ$).

finding ρ'_{max} is the eqn. (9) but not the eqn, (23). In other words for the ratios of L/d less than the mentioned one, to determined ρ'_{max} , the governing equation is the eqn. (23) but not the eqn, (9). Whereas, while using the $\phi = \phi' = 10\text{mm}$, for all the values of L/d , the eqn. (9) is the governing equation for finding ρ'_{max} . Considering the case of the simply supported beams, and for bars diameter equal to the 10 and 25mm, for all the values of L/d , the eqn. (9) is the governing equation.

4.4 Concrete and Reinforcement Strengths

Fig. 4 shows the maximum compression

reinforcement ratio for $f'_c = 50 - 90$ MPa, $f_y = 400$ and 500MPa , $L/d=10$ and a uniformly distributed load. The figure shows that, as expected, the higher the steel yield stress, the lower value of ρ'_{max} is obtained. An increase of the steel yield stress also increases the range of concrete strength at which ρ'_{max} is determined by the congestion criterion eqn. (9) rather than by the diagonal compression eqn. (23). In the current example, for $f_y = 400$ MPa, ρ'_{max} is determined by eqn. (23) for $f'_c \leq 55$ MPa (and by eqn. (9) for $f'_c > 55$ MPa), while for $f_y = 500$ MPa steel congestion eqn. (9) is determines ρ'_{max} for all f'_c . Accordingly, higher concrete strength

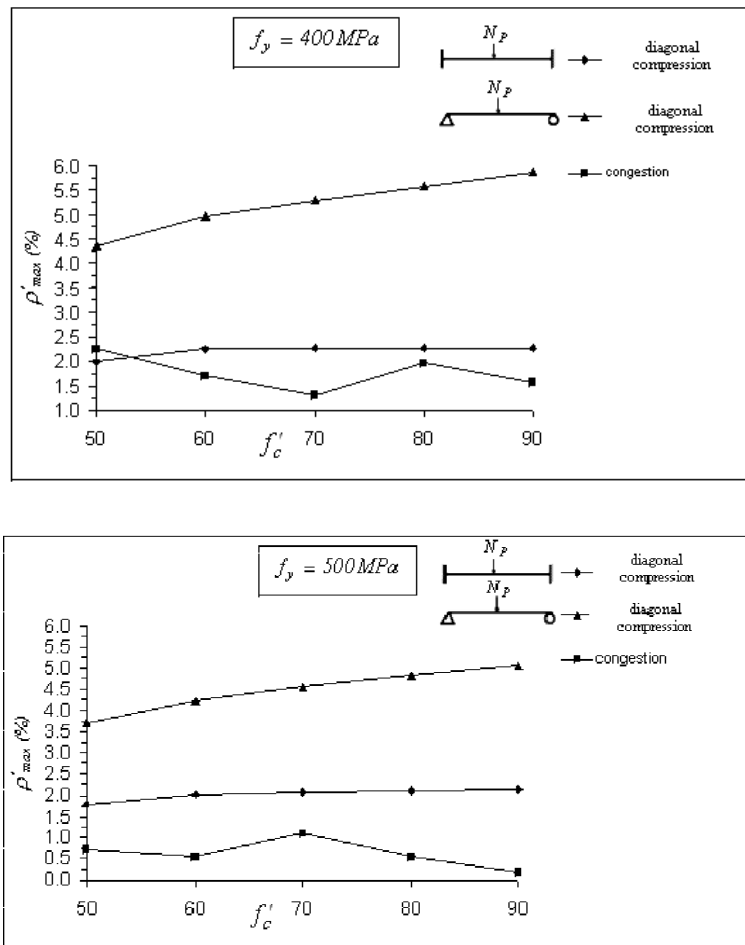

Fig.4. Effect of concrete and steel strength on ρ'_{max} for Fixed Ended beam and simply supported beam loaded with uniformly distributed load ($h=800\text{mm}$, $b=400\text{mm}$, $L/d=10$, $\phi = \phi'=25$, $\alpha = 90^\circ$).

increases ρ'_{max} as long as it is set by the diagonal compression criterion eqn. (23), while it hardly depends on f'_c when it is set by the congestion criterion eqn. (9) (Fig. 4). It is also obvious from Fig.4 that, by increase the concrete strength f'_c , the values of ρ'_{max} (based on the eqn. (23)) will be more increased in simply supported beams with respect to the Fixed Ended beams conditions.

5. Conclusions

A quantitative measure to evaluate an upper limit to the compression reinforcement ratio ρ'_{max} of flexural HSRC members is proposed.

It is shown that a quantitative criterion to ρ'_{max} can be derived from steel congestion and proficient-design consideration eqn. (9) and from considerations related to diagonal compression bearing capacity eqn. (23). Parameters that affect this limit include the concrete and steel strengths, the beam's geometry (L/d ratio, cross section's dimensions, and concrete cover), the reinforcement diameter, and the moment-to-shear loading ratio (or the loading type) and the types of the beam's end conditions.

When shear loading is dominant, the limit to ρ' is set by the diagonal compression criterion. The expressions that were derived

provide additional tool for a better design and assessment of the flexural capacity of HSRC members with compression reinforcement. It was also concluded that, comparing the simply supported beams with the Fixed Ended beams of HSC, the values of ρ'_{max} will be more increased.

The use of HSC, by increasing the concrete strength, the values of ρ'_{max} which is obtained by congestion criterion of equation (9), are not in a regular manner.

6. References

- [1] American Concrete Institute (ACI), “Building Code Requirements for Structural Concrete” and “Commentary”, ACI 318_02 and ACI 318R_02, 2002.
- [2] European Committee for Standardization (CEN), “Design of Concrete Structures, part1, General Rules and Rules for Buildings (together with UK NAD)”, Euro code 2, 1992, London.
- [3] AS3600, “Australian Standard for Concrete Structures, AS3600”, Standard Australia, 1994, Sydney.
- [4] Lin, C.h. and Furlong, R.W, “Longitudinal Steel Limits for Concrete Columns”, ACI Struct.J, V.92, No.3, 1995, pp. 282-287.
- [5] Dancygier, A.N and Eid, R., “Upper Limit to Compression Reinforcement Ratio in Flexural Elements”, Journal of Structural Engineering, V.127, No.1, 2001, pp. 58-63.
- [6] Maghsoudi, A.A and Akbarzadeh-

Bengar, H., “Upper Limit to Compression Reinforcement Ratio in Flexural HSC Elements”, Proceeding of First National Congress in Civil Eng., Sharif University, Tehran, Iran, May 2004, paper’s code 83-1332.

- [7] Maghsoudi, A.A and Akbarzadeh, H., “Upper Limit to Compression Reinforcement Ratio in Flexural HSC Elements”, International Journal of Civil Engineering (Accepted).
- [8] Nielsen, M.P, “Limit Analysis and Concrete Plasticity”, Prentice-Hall, Englewood Cliffs, 1984, N.j.
- [9] CEB-FIP Model Code 1990 (Mc90), “Commit Euro-international du béton”, 1990.

Appendix A: Examples

Example 1:

A Fixed ended reinforced concrete beam that carries uniform load is shown in Fig. 5 with the following properties:

$$L=6000 \text{ mm}$$

$$b=400 \text{ mm}$$

$$h=800 \text{ mm}$$

$$d=750 \text{ mm}$$

$$f'_c=80 \text{ MPa}$$

$$f_y=400 \text{ MPa}$$

$$L/d=8$$

Inclination of shear-reinforcement tie is 90° . Use ϕ_{25} as tensile and compressive bars, calculate the maximum amount of ρ' for the sections A-A and B-B.

The example can be solved using the diagram shown in Fig. 3:

It is easily possible to find out the maximum amount of ρ' while, beam is Fixed ended,

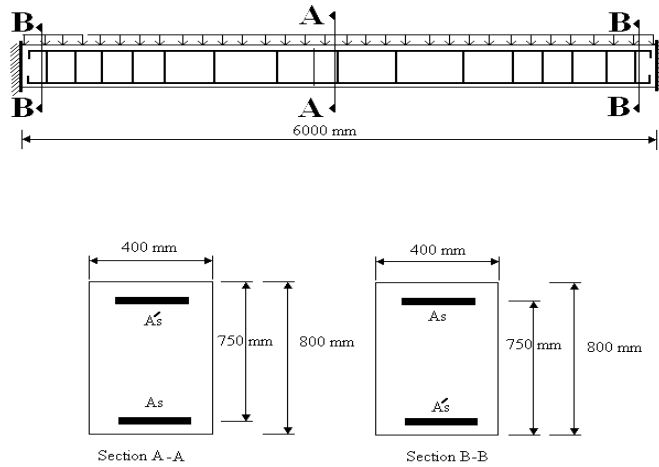

Fig.5. Beam dimensions for section A-A and B-B.

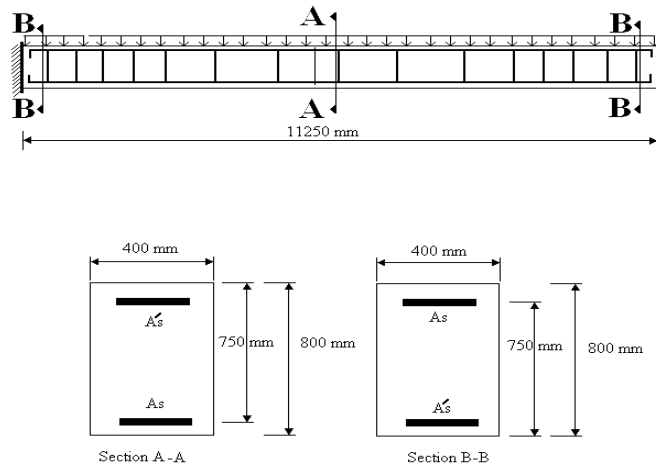

Fig.6. Beam dimensions for section A-A and B-B

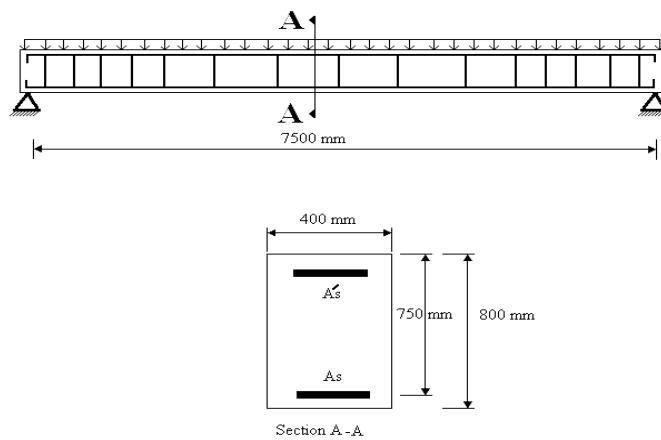

Fig.7. Beam dimensions for section A-A

$N_p \rightarrow \infty$, $b=400$ mm, $h/b=2$, $L/d=8$, $\alpha=90^\circ$, $f_y=400$ MPa, $f'_c=80$ MPa and assuming ϕ_{25} for ρ and ρ' . Hence, the maximum amount of ρ' based on steel congestion criterion is found out Fig. 3 as 2.0% but maximum amount of ρ' based on diagonal compression criterion is found out Fig. 3 as 1.0%. Therefore, ρ'_{max} is set by diagonal compression criterion ($\rho'_{max}=1.0\%$).

Example 2:

A Fixed ended reinforced concrete beam that carries uniform load is shown in Fig. 6 with the following properties:

$$\begin{aligned} L &= 11250 \text{ mm} \\ b &= 400 \text{ mm} \\ h &= 800 \text{ mm} \\ d &= 750 \text{ mm} \\ f'_c &= 80 \text{ MPa} \\ f_y &= 400 \text{ MPa} \\ L/d &= 15 \end{aligned}$$

Inclination of shear-reinforcement tie is 90° . Use ϕ_{25} as tensile and compressive bars, calculate the maximum amount of ρ' for the sections A-A and B-B.

The example can be solved using the diagram shown in Fig. 3:

It is easily possible to find out the maximum amount of ρ' while, beam is Fixed ended, $N_p \rightarrow \infty$, $b=400$ mm, $h/b=2$, $L/d=15$, $\alpha=90^\circ$, $f_y=400$ MPa, $f'_c=80$ MPa and assuming ϕ_{25} for ρ and ρ' . Hence, the maximum amount of ρ' based on steel congestion criterion is found out Fig. 3 as 2.0% but maximum amount of

ρ' based on diagonal compression criterion is found out Fig. 3 as 5.5%. Therefore, ρ'_{max} is set by steel congestion criterion ($\rho'_{max}=2.0\%$).

Example 3:

A Simple supported reinforced concrete beam that carries uniform load is shown in Fig. 7 with the following properties:

$$\begin{aligned} L &= 7500 \text{ mm} \\ b &= 400 \text{ mm} \\ h &= 800 \text{ mm} \\ d &= 750 \text{ mm} \\ f'_c &= 50 \text{ MPa} \\ f_y &= 400 \text{ MPa} \\ L/d &= 10 \end{aligned}$$

Inclination of shear-reinforcement tie is 90° . Use ϕ_{25} as tensile and compressive bars, calculate the maximum amount of ρ' for the sections A-A.

The example can be solved using the diagram shown in Fig. 4:

It is easily possible to find out the maximum amount of ρ' while, beam is Simple supported with uniformly distributed load, $b=400$ mm, $h/b=2$, $L/d=10$, $\alpha=90^\circ$, $f_y=400$ MPa, $f'_c=50$ MPa and assuming ϕ_{25} for ρ and ρ' . Hence, the maximum amount of ρ' based on steel congestion criterion is found out Fig. 4 as 2.0% but maximum amount of ρ' based on diagonal compression criterion is found out Fig. 4 as 4.25%. Therefore, ρ'_{max} is set by steel congestion criterion ($\rho'_{max}=2.0\%$).