

Modern Control Design of Seismically Excited Tall Buildings with Uncertain Dynamic Characteristics

Fereidoun Amini¹, Reza Vahdani²

¹Associate Professor, Email: famini@iust.ac.ir

²Ph.D Student

Department of Civil Engineering, Iran University of Science and Technology, Narmak, Tehran, PO16844

Abstract: In this research, an innovative numerical simulating approach for time domain analysis of multi degrees of freedom structures with uncertainty in dynamic properties is presented. A full scale finite element model of multi-story and multi bays of three sample structures has been constructed. The reduced order model of structure with holding the dominant and effective Gramians in the balanced state-space realization has been achieved for easy and safe design of the optimal control forces applied to the structure. Some easy selective control algorithms based on the Optimal-Stochastic control theories such as LQG, DLQRY and modified sliding mode control has been programmed with the simulation control sequences. Some real features of accurate control system such as time delay and noise signals in earthquake time histories and also measurement sensors are considered in illustrative simulation models. These models can be analyzed under either various intensity of corresponding earthquakes or desired random excitations passed through the suitable filters providing stochastic parameters of earthquake disturbances. This control procedure will be shown to be very efficient suppressing all the severities and difficulties may arise in design of a multi-objective optimal control system. The obtained results illustrate the feasibility and applicability of the proposed stochastic optimal control design of active control force providing a stable and energy-saving control strategy for tall building structures.

Keywords: Stochastic Optimal Control, Tall Buildings, Noisy Seismic Disturbance.

1. Introduction

Tall buildings with excessive degrees of freedom under severe external disturbances such as strong ground motion or huge wind turbulence need to be protected against large drifts and occupants disturbing vibrations. Supplemental devices such as MR/ER dampers could be installed on the desired floors to reduce relative displacements and absolute accelerations of the floors. To design of these elements, a comprehensive simulating procedure should be implemented in simultaneous types such as control algorithm, sensors, input-output relations and evaluation criterion to illustrate the efficiency and applicability of the chosen control strategies. Recently, an innovative branch of modern control theories have been conducted for modeling and simulating of the

executive control package including of optimal control design of the actuator parameters and evaluation of controlled responses [1]. The state-space representation of the dynamic equilibrium equations of the structure and controllers which can be modeled as assembled desired state variables of the structure and controllers and interaction between them, is a successful executable block box in the body of simulation procedure [2]. The concept of digitalized state-space controllers with comprehensive state-feedback optimal control law could be setting on the simulator to emission the control command vector to reduce the evaluation response of the structure. This control simulation could model the uncertainty in dynamic characteristics of the structure and actuators such as variations of stiffness or mass

matrices from true central values. Dynamic interaction between the model and the actuators are being considered in obtaining the control forces. In other words, control system is operating robustly with respect to the ground motion intensity. Besides, Uncertainty in dynamic characteristics of the model as well as the actuators is controlled via a stochastic optimal control procedure. These two contributions make the research more realistic.

Furthermore, we can select both of the realistic time history analysis with earthquake records and also stochastic analysis with white noise spectral generated by filtered random excitation. In order to achieve more practical results, Dynamic behavior of the actuators is simulated in modeling procedure. This gives the opportunity to simultaneously follow up dynamic behavior of both structure and actuators.

The reduction method namely balance realization technique is combined with optimal control design for the first time. It is found that the technique results in computational efficiency and minimizing error signals feed to the compensators.

For numerical solution of state-space equations of structure-actuators we have intended the famous digitalized methods in modern control analysis such as first-order, zero-order or "Tustin", Pre warping frequency-based approximation methods to linearization of control-influenced loading [3]. To demonstrate the capability of the proposed control strategies, three samples mid to high rise steel structures modeled with active-tendon and active mass dampers installed on designer's defined locations on the floors. Control routines indeed Linear Quadratic Guassian with LTR (Loop Transfer Recovery) compensators and

modified sliding mode control procedure[4], which have good applications in stochastic control of uncertain structures have been implemented to determine the required control forces. In this multi objective optimal design of controllers, it has been calculated the best required control actions in full-scale model of structure-actuators which minimized the all of the control performances and evaluation criterion such as actuators capacities, power of controllers, response limitations and etc. One of the interesting features of the corresponding control program is the flexibility to selecting various types of active, semi active or hybrid control devices in the block control section of the simulation. On the other hand, researchers can select the important state variables in the case of control output, measurement vectors, evaluation state vectors and feedback control regulated vectors to assigning the deliberate control policy in synthesis of efficacy of the control medium. Verifying results indicate that this control procedure is very vibration suppressing and robust with respect to measurement noises and fluctuations of undesirable seismic excitations.

2. Formulation

To optimal design of controllers, we try to reduce the state-space model of structure-actuators with balance realization of state-space model in sense of holding the dominant Gramians of solution from Lyapunov energy-based equilibrium equation in dynamic equation of motion [5].

The equation of motion for the evaluation model, including damping, can be expressed as

$$M_s \ddot{Z}_s + C_s \dot{Z}_s + K_s Z_s = -M_s \Gamma \ddot{x}_g + H U_c \quad (1)$$

Here, Z_s = vector of active DOF; and M_s, C_s , and K_s are mass, damping, and stiffness matrices of the structural system, respectively. U_c = vector of control force inputs, \ddot{x}_g = ground acceleration collinear with the longitudinal axis of the structure, Γ = vector distributing the ground acceleration to the structural system, H matrix defining how the force(s) produced by the control device(s) enter the structural system. The state-space equations take the form

$$\dot{X}_s = A_e X_s + B_e \ddot{x}_g + E_e U_c \quad (2)$$

Where

$$X_s = \begin{bmatrix} Z \\ \dot{Z} \end{bmatrix}, \quad A_e = \begin{bmatrix} 0_{n \times n} & I_{n \times n} \\ -M_s^{-1} K_s & -M_s^{-1} C_s \end{bmatrix}, \quad (3)$$

$$B_e = \begin{bmatrix} 0_{n \times 1} \\ -\Gamma \end{bmatrix}, \quad E_e = \begin{bmatrix} 0_{n \times r} \\ M_s^{-1} H \end{bmatrix}$$

and the measurement and regulated output equations may be obtained as, respectively,

$$y_s = C^y_e X_s + D^y_e \ddot{x}_g + F^y_e U_c + V_r \quad (4)$$

$$z_s = C^z_e X_s + D^z_e \ddot{x}_g + F^z_e U_c \quad (5)$$

Here, y_s =vector of measured responses and C^y_e, D^y_e , and F^y_e = measurement system matrices; similarly, V_r =measurement noise vector, z_s = regulated output vector and C^z_e, D^z_e , and F^z_e = measurement system matrices. As mentioned above, in the interest of efficiency, a reduced order representation of the evaluation model was developed for control design. The reduced order model was formed through balanced realization of the system and subsequent condensation of the states with relatively small Controllability and Observability grammians using the ‘‘balreal’’ and ‘‘modred’’ functions in MATLAB. Reducing the model is based on the numerical solution of nonlinear coupled

matrix controlability and observability equations in Lyapanov sense for the full order structure-actuator system. In order to obtain the dominant weighting vectors corresponding to the coded states hold in the reduced system, we used the numerical solution of the real-time updated of pre-mentioned equations. The state equations of the balanced system can be represented as

$$\dot{X}_{sr} = A_{er} X_{sr} + B_{er} \ddot{x}_g + E_{er} U_c \quad (6)$$

$$y_m = C^y_{er} X_{sr} + D^y_{er} \ddot{x}_g + F^y_{er} U_c + V_r \quad (7)$$

$$z_r = C^z_{er} X_{sr} + D^z_{er} \ddot{x}_g + F^z_{er} U_c \quad (8)$$

2.1. Design of Controllers Based on LQG-DLQRY Optimal Control Theories

Based on stochastic optimal control theory, a state feedback LQG controller is obtained by minimizing the quadratic objective function shown as

$$J = \lim_{\tau \rightarrow \infty} \frac{1}{\tau} E \left[\int_0^{\tau} (\bar{z}^T Q \bar{z} + U_c^T R U_c) dt \right] \quad (9)$$

In which, $\bar{z} = z_r - D^z_{er} \ddot{x}_g = C^z_{er} X_{sr} + F^z_{er} U_c$, $Q = (n_{zr} \times n_{zr})$ diagonal output feedback state matrix, and $R = 5 \times 10^{-8} \text{diag}(n_{Uc} \times n_{Uc})$. Minimizing the objective function in Eq. (9), the optimal controller is obtained as [6].

$$U_c = K_{Fb} X_{sr}, \quad K_{Fb} = -\bar{R}^{-1} (B_{er}^T P_c + \bar{S}^T) \quad (10)$$

Where P_c is the solution of the modified Riccati matrix equation which formed as

$$P_c \bar{A} + \bar{A}^T P_c - P_c B_{er} \bar{R}^{-1} B_{er}^T P_c + \bar{Q} - \bar{S} \bar{R}^{-1} \bar{S}^T = 0 \quad (11)$$

In which, $\bar{Q} = C^z_{er}{}^T Q C^z_{er}$; $\bar{R} = F^z_{er}{}^T Q F^z_{er} + R$;

$$\bar{S} = C^z_{er}{}^T Q F^z_{er}; \quad \bar{A} = A_{er} - B_{er} \bar{R}^{-1} \bar{S}^T$$

2.1.1. Optimal Observer Design

The controller obtained in Eq. (10) requires the reduced-order state feedback X_{sr} , which can be estimated from an observer, denoted by \hat{X}_{sr} , based on the separation principle. The Kalman-Bucy filter can be designed to estimate \hat{X}_{sr} as follows [7]:

$$\dot{\hat{X}}_{sr} = A_{er} \hat{X}_{sr} + B_{er} U_c + L_{obs} (y_m - C^y_{er} \hat{X}_{sr} - F^y_{er} U_c) \quad (12)$$

in which the observer gain matrix L_{obs} is obtained from

$$L_{obs} = (P_0 C^y_{er}{}^T + S_0) R_0^{-1} \quad (13)$$

where P_0 is the solution of the Riccati matrix equation which concluded as

$$P_0 A_0 + A_0^T P_0 - P_0 C^y_{er}{}^T R_0^{-1} C^y_{er} P_0 + Q_0 - S_0 R_0^{-1} S_0^T = 0$$

$$A_0 = A_{er}{}^T - C^y_{er}{}^T R_0^{-1} S_0^T \quad (14)$$

In Eqs. (13)-(14), Q_0 and $R_0 =$ autopower spectral density matrices of two vectors $B_{er} \ddot{x}_g$ and $D_{er}^y \ddot{x}_g + V_r$, respectively; and S_0 is the cross-power spectral density of two vectors $B_{er} \ddot{x}_g$ and $D_{er}^y \ddot{x}_g + V_r$. These matrices are given by

$$Q_0 = B_{er} \bar{S}_{\ddot{x}_g \ddot{x}_g} B_{er}{}^T; \quad S_0 = B_{er} \bar{S}_{\ddot{x}_g \ddot{x}_g} D^y_{er};$$

$$R_0 = \bar{S}_{V_r V_r} + D^y_{er} \bar{S}_{\ddot{x}_g \ddot{x}_g} D^y_{er}{}^T \quad (15)$$

Where $\bar{S}_{\ddot{x}_g \ddot{x}_g}$ and $\bar{S}_{V_r V_r}$ are the power spectral density matrices of the white noises \ddot{x}_g and V_r respectively, for the design purpose. For the observer design, $\bar{S}_{\ddot{x}_g \ddot{x}_g}$ and $\bar{S}_{V_r V_r}$ can be scaled appropriately for convenience of numerical computations. For this sample controller, we choose $\bar{S}_{V_r V_r} = \text{diag}[0.15, 0.15, 0.15]$ and

$$\bar{S}_{\ddot{x}_g \ddot{x}_g} = \alpha \cdot |S_{\ddot{x}_g \ddot{x}_g}(\omega)| = 1.756 \times 10^{-3} |\bar{S}_a(\omega) \bar{S}^{T*}(\omega)|$$

at $\omega = 3.65$ rad/sec, where $S_{\ddot{x}_g \ddot{x}_g}(\omega)$ is the cross-power spectral density matrix of seismic records and $\bar{S}_a(\omega)$ is the Fourier transform of the ground acceleration records.

2.2. Design of Controllers Based on the Modified Sliding Mode Control

The idea of sliding mode control is to drive the response trajectory into a sliding surface on which the motion of the system is designed to be stable, and to maintain the trajectory on the sliding surface for all subsequent times. In designing of co-state coefficients of modified sliding surfaces, non-stationary solutions of the Generalized Riccati Equation are obtained in all sequences of the control procedure. This approach guarantees the stability and reliability of the control design forces.

In this case, the observer equation can be written as

$$\dot{\hat{X}}_a = A_a \hat{X}_a + B_a U_c + \bar{E} \varepsilon(t) \quad (16)$$

Where

$$X_a = \begin{bmatrix} X_{sr} \\ U_c \end{bmatrix}; \quad A_a = \begin{bmatrix} A_{er} & E_{er} \\ 0 & A_U \end{bmatrix}; \quad B_a = \begin{bmatrix} 0 \\ B_{Uc} \end{bmatrix};$$

$$\bar{E} = [L_{obs} \bar{C}^y_{er} \quad L_{obs} D^y_{er} \quad L_{obs}]$$

Above augmented coupled system composed of the pre-filter control force command generated with equation $\dot{U} = A_U U + B_{Uc} U_c$ and Gaussian white noise disturbance process $\varepsilon(t) = [e(t) \ddot{x}_g V(t)]^T$.

In which, $e(t) = X_a(t) - \hat{X}_a(t)$ is the estimation error that should be minimized. Modified sliding mode control and stochastic optimal control are complementary supporting each other. This contribution makes the system more stable and increases convergence in prediction of the error signals. The scalar sliding surface can be expressed in terms of

the observer states, $\dot{\hat{X}}_a$, i.e.[8],

$$S = P\dot{\hat{X}}_a = [P_1 \ P_2] \begin{bmatrix} \dot{\hat{X}}_{sr} \\ \dot{\hat{U}} \end{bmatrix} \quad (17)$$

Where, $P_1 = \bar{R}^{-1}(E_{er}^T P_c + \bar{S}^T)$ and $P_2 = I_{n_{uc}}$ (Identity matrix). By following the concept of Lyapunov stability, a Lyapunov function $V=0.5S^T S$ is constructed and the sliding mode control command U_c is designed to ensure that $\dot{V} \leq 0$ at every time instant to guarantee that the sliding surface S will be approaching zero gradually. Using Eqs. (16) as well as the condition $\dot{V} \leq 0$, the continuous sliding mode controller U_c can be expressed as, [9]

$$U_c = K_{fb} \hat{X}_a + K_{FF} \varepsilon(t) = -(PB_a)^{-1} PA_a - \delta B_a^T P^T P \hat{X}_a - (PB_a)^{-1} P \bar{E} \quad (18)$$

In the above control command, $\delta > 0$ is the gain margin. Likewise, the trajectory of the controlled response will oscillate in the vicinity of the sliding surface, i.e. $S=0$. The choice of δ depends on the uncertainty bound of the structural system. In other words, a bigger δ should be designed for structures with bigger uncertainty to ensure the robustness of the system.

2.3. Control Constraints for Active Tuned Mass Damper

In order to make the structural models as realistic as possible, the following implementation constraints are imposed on the proposed control design of ATMD:

- In principle, acceleration of all floors can be measured for feedback to determine the control action. However, for convenience of full-order model comparison, only the 22 variables from third model structure in the measured output Y_s defined by Eq. (4) can be available. Further, a maximum of six sensors

is used. In other words, one has the mathematical limit in assigning of suitable degrees of freedom from structural model to choose at most six variables in Y_s as the feedback quantities for the determination of the control action. In the case of velocity feedback, the acceleration sensor is used and the velocity is obtained by numerical integration.

- The controller is digitally implemented with a sampling time of $\Delta t=0.001$ sec.

- A computational time delay of 2 milli-sec is considered for the simulation of response.

- The measurement noises are modeled as Gaussian rectangular pulse processes with a pulse width of 0.001 sec and a two sided spectral density of 10^{-9} $m^2/s^4/Hz$, when acceleration sensors are used. This corresponds to a diagonal covariance matrix in which each diagonal element is 10^{-9} $\delta(\tau)$ m^2/s^3 , where τ is the time interval between two time instants considered. The measurement noise level for each acceleration sensor considered above corresponds to approximately 1-6% of the uncontrolled acceleration response of the building or about 2.5-15% of the controlled acceleration response.

- To limit the computational resources, the compensator for the controller in Eqs. (19) and (20) is restricted to have no more than 12 states and the compensator is required to be stable.

- The natural frequency and damping ratio of ATMD (or TMD) are design parameters that can be chosen by the designer.

2.4. Discrete Controllers/Compensators Design Problem

The problem of controller design is to determine a discrete-time feedback compensator of the form

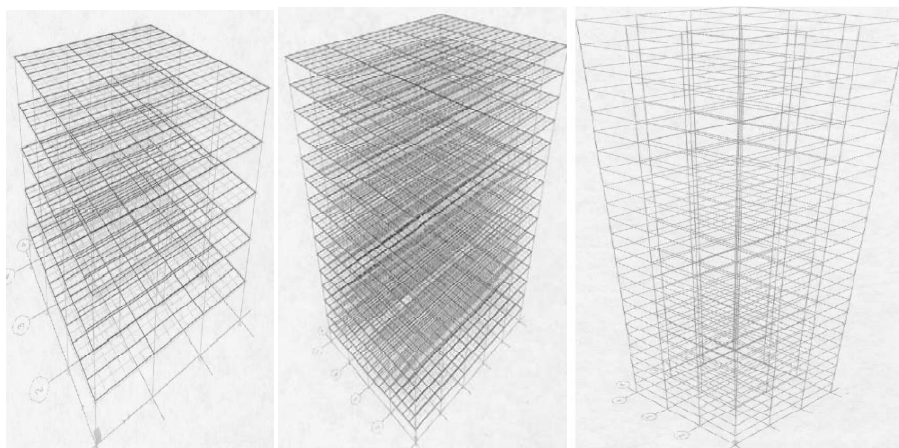

Fig.1 Three samples moment resisting frames of 5, 15, and 25 story 3-D steel structure models for implementing the required controllers.

$$X_c(k+1) = G_1[X_c(k), \tilde{y}_m(k), U_c(k), k] \quad (19)$$

$$U_c(k) = G_2[X_c(k), \tilde{y}_m(k), k] \quad (20)$$

Where, $X_c(k)$, $\tilde{y}_m(k)$, and $U_c(k)$ = vector of the compensator, selected measurement output vector, and the control force, respectively, at time $t=k\Delta T$ with ΔT being the sampling time for the compensator. Although the reduced-order system in Eq. (6), the controlled output vector Z_r , i.e. Eq.(8), and the measured output vector y_m in Eq. (7) are provided herein, the designers are free to establish their own reduced-order system, controlled output feedback vector, and measured output vector using different approaches. Finally, the controllers in Eqs. (10)-(12) is converted to the form in Eqs. (19) and (20) as follows:

$$X_c(k+1) = A_c X_c(k) + B_c y_m(k) \quad (21)$$

$$U_c(k) = C_c X_c(k) + D_c y_m(k) \quad (22)$$

3. Problem Definition

Three samples include 5, 15 and 25 stories of moment resisting frame steel structures with appropriately seismic design of their

members have been considered. The finite element subprograms which produced the stiffness, damper and mass matrices of the structures have been edited. The state reduced-order design model and evaluation equations with appropriate adjusted matrices have been performed for preparing the pre-calculated parameters of the simulation flowcharts. Figure 1, shows the three types of control instruments which can be installed on each floor of the multi-story structures as modeled in simulation procedure. The location on the structure and an appropriate model must be specified for each control device and sensor employed. Passive, active and semi-active devices, or a combination thereof, may be considered. For illustrative purposes a complete sample control design is presented. Although this sample control system it not intended to be competitive, it demonstrates how one might define and model the sensors and control devices employed, build a design model, and evaluate a complete control system design.

3.1. Structural Identifications

These sample steel frame structures were constructed with MRF 3-D structure system

with 3.65m height of each story and the bays are 6.10m center to center, in both direction. The plan areas for all stories are simultaneously generated in height as 335m² at first and third model and for second model is 930.25m². The columns are 345 Mpa steel. The interior columns of the MRF are wide-flange. The corner columns are box columns. The column lines employ three-tier construction, i.e. monolithic column pieces are connected every three levels beginning with the second story. Column splices in third model to carry bending and uplift forces, are located on the 2nd, 5th, 8th, 11th, 14th, 17th and 22nd stories at 1.9m above the center-line of the beam to column joint. The floors are composite construction (i.e., concrete and steel). In accordance with common practice, the floor system, which provides diaphragm action, is assumed to be rigid in the horizontal plane. The floor system is comprised of 248 Mpa steel wide-flange beams acting compositely with the floor slab. The inertial effects of each level are assumed to be carried evenly by the floor diaphragm to each perimeter "MRF", hence each frame resists one fourth of the seismic mass associated with the entire structure [10].

The seismic mass of the structure is due to various components of the structure, including the steel framing, floor slabs, mechanical/electrical, partitions, roofing and a penthouse located on the roof. The seismic mass of the first level is 5.4×10^5 kg, for the second level is 5.7×10^5 kg, for the third level to 25th level is 5.5×10^5 kg, and for the roof is 5.8×10^5 kg. The seismic mass of the entire structure for 25-story building model is 1.45×10^7 kg.

Duration of time histories for both the deterministic and stochastic analysis for the evaluation model and the control design model were considered 100 sec to completely

diminish the small amplitude of ground acceleration and the measurement noises. The time intervals for numerical simulation of structure and digital compensators have been assumed 0.001 sec and 0.005 sec respectively which satisfied the convergence and stability criterion of the numerical integration solvers.

The Simulating model shown in Fig. 2 has been developed to simulate the features and limitations of the structural control problem above and to compute both the "root-mean-square" (RMS) and peak response quantities as well as the performance indices.

4. Numerical Results

For a comprehensive investigation, four well-known earthquake which have distinct frequency contents and magnitudes, two far-field and two near-field historical records were selected as input excitations: (i) El-Centro: The N-S component recorded at the Imperial Valley Irrigation district substation in El-Centro, CA, May 18, 1940. (ii) Kobe: The N-S component recorded at the Kobe JMA station during the Hyogoken Nanbu earthquake of January 17, 1995. (iii) Tokachi-oki (Hachinohe) Earthquake: North-south component recorded at Hachinohe City during the Tokachi-oki Earthquake of May 16, 1968. (iv) Northridge: The N-S component recorded at the Sylmar, CA, during the Northridge, CA earthquake of January 17, 1994. These time histories applied to the base of the sample structures individually with various random magnification factors. The nonlinear controlled response of the 5th, 15th, and 25th floors of third sample model structure subjected in El-Centro Earthquake were shown in figure 3. Robustness is the most important outcome of the stochastic optimal

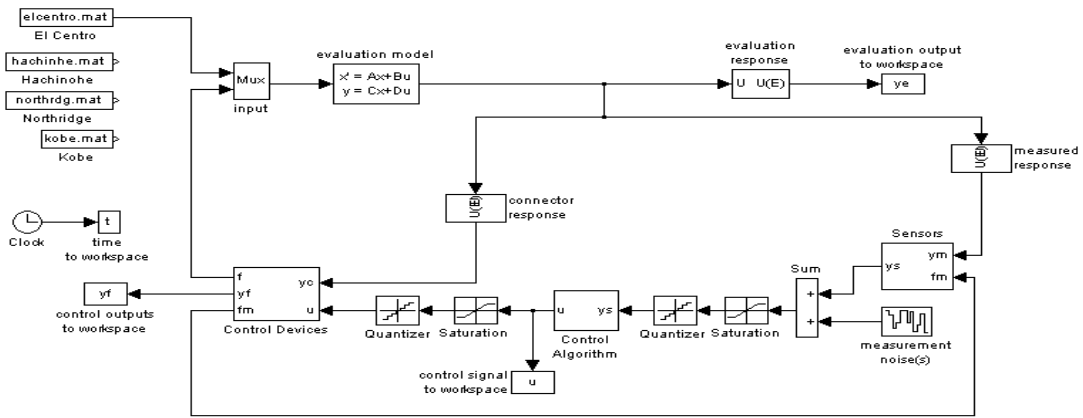

Fig.2 The Simulink Flow Diagram to model the building, Control devices, Sensors, and the selective Seismic Excitations.

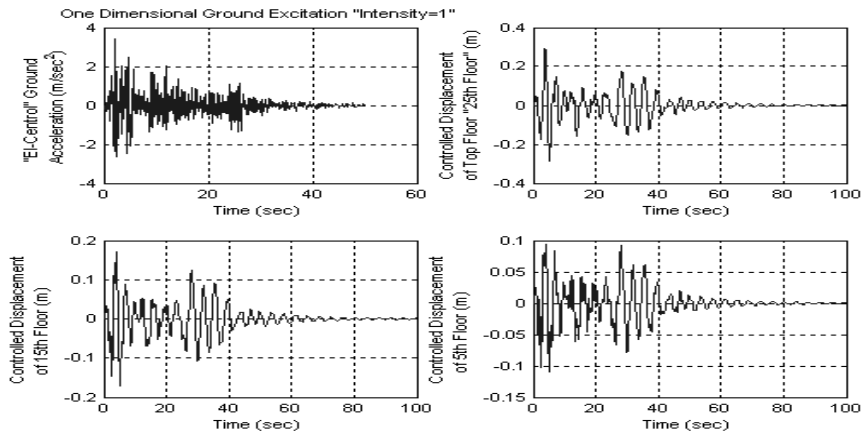

Fig.3 Controlled responses of the various floors of 25-story building under El-Centro Earthquake.

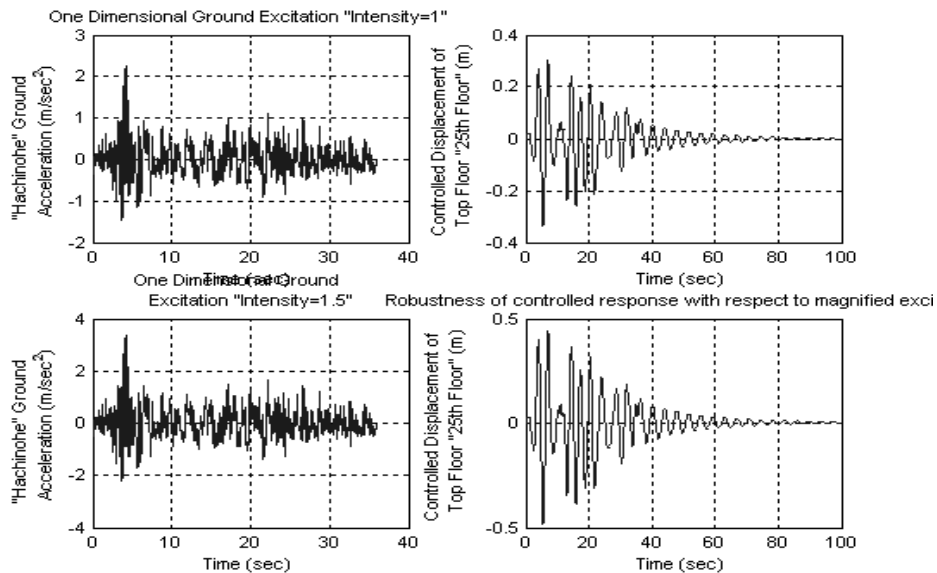

Fig.4 Assessment of control robustness of proposed Algorithm with respect to amplification of seismic Excitation. (Hachinohe Earthquake, Intensity=1 and Intensity=1.5).

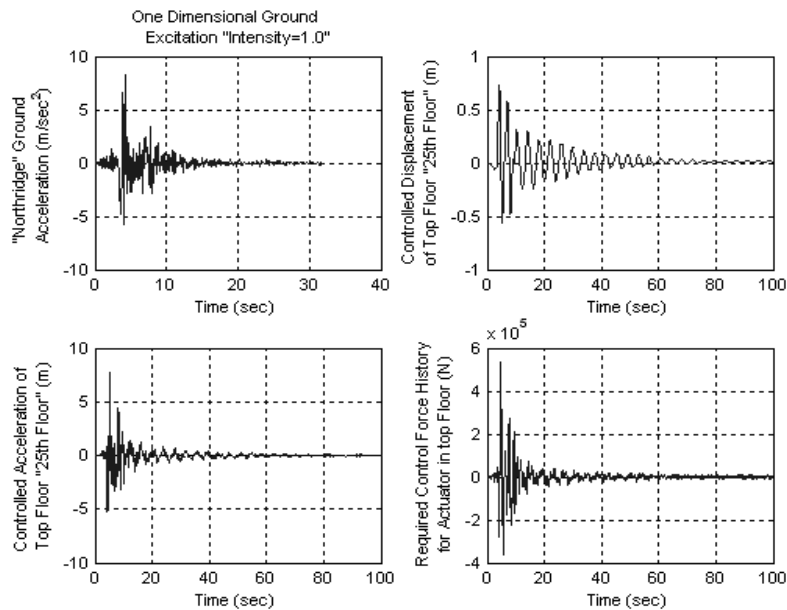

Fig.5 Controlled responses (i.e. Displacements & Accelerations) and required optimal control force histories of top floor of 25-story sample model under Northridge Earthquake excitation (Intensity=1.0).

control procedure. It means the resistance and uniform performance of the designed control system with respect to uncertain dynamic characteristics of the system or actuators like their mass, stiffness and damping as well as uncertainty in input signals. Furthermore, the robustness of controlled response of top floor of structure with respect to fluctuation and uncertain magnification of seismic excitation specified in Hachinohe Earthquake which applied to the structure have been demonstrated in Figure 4. In order to verify robustness of the designed controller system, some uncertainty in input acceleration as well as the dynamic characteristics of the system have been implemented and the performance of the system has been proved to be robust with respect to their fluctuations. The level of uncertainty in the base acceleration and the structure stiffness are selected to be +50% and $\pm 18\%$ respectively. In order to achieve this goal, the singular value minimization is carried out in transfer functions of plant and compensators in sense on MIMO system,[11].

The optimal control force history of AMD installed on top floor of model has been shown in Figure 5 calculated in presence of -14% uncertainty margins in stiffness matrix of structure which satisfied occupant comfort conditions and desired limit of controlled response of the structure. Some control performance criterion as mentioned with “J” which indicated the successful ability control procedure of structure were calculated and presented in table 1. These indices which calculated based on division of stochastic or deterministic components of controlled output such as floor displacement, floor acceleration, Actuator control forces, etc, with respect to maximum uncontrolled corresponding value of relative Component. For example, J1 is related to the Peak inter-story drift control,[12]

Evaluation criteria which are minimized in our proposed stochastic optimal control procedure make from divided controlled candidate floors displacements to maximum uncontrolled floor displacement (Top Floor). J2 is representative peak floor acceleration,

Table 1 Verified control performances between two proposed control approaches, i.e. LQG and SMC subjected to intensified Earthquake Ground motions.

| | El-Centro | | Hachinohe | | Northridge | | Kobe | | | | | | | |
|-----------------|---------------|---------------|---------------|---------------|---------------|---------------|---------------|---------------|--------|--------------|--------|--------------|--------|--------------|
| | Intensity:1.0 | Intensity:1.5 | Intensity:1.0 | Intensity:1.5 | Intensity:1.0 | Intensity:1.5 | Intensity:1.0 | Intensity:1.0 | | | | | | |
| | LQG | SMC | LQG | SMC | LQG | SMC | LQG | SMC | | | | | | |
| J1 | .8028 | .786 | .7804 | .747 | .8870 | .8341 | .9066 | .8762 | .9421 | .924 | .8161 | .7912 | .7278 | .6941 |
| J2 | .5090 | .4762 | .5043 | .4876 | .7429 | .7032 | .8327 | .7954 | .9043 | .8781 | .7021 | .6841 | .8391 | .8002 |
| J3 | .8462 | .8102 | .9662 | .9308 | .9819 | .9251 | 1.0091 | .9741 | .9694 | .9352 | .9250 | .8821 | 1.0565 | .9695 |
| J4 | .7917 | .7561 | .7972 | .7631 | .8840 | .8462 | .9027 | .8762 | .9295 | .9004 | .6477 | .6100 | .2303 | .1114 |
| J5 | .4626 | .4231 | .4715 | .4473 | .6516 | .6214 | .6615 | .6245 | .6366 | .6058 | .5789 | .5412 | .7129 | .6792 |
| J6 | .7841 | .7325 | .7857 | .7562 | .8479 | .8015 | .8577 | .8124 | .8408 | .8165 | .6887 | .6387 | .8404 | .8147 |
| J7 | .0035 | .0046 | .0051 | .0064 | .0035 | .0048 | .0051 | .0064 | .0082 | .0089 | .0050 | .0061 | .0089 | .0095 |
| J8 | .0866 | .0895 | .0873 | .0905 | .0758 | .0802 | .0805 | .0825 | .1031 | .1204 | .1261 | .1474 | .1142 | .1276 |
| J9 | .0017 | .0022 | .0025 | .0030 | .0017 | .0021 | .0026 | .0031 | .0051 | .0057 | .0040 | .0046 | .0088 | .0095 |
| Y | .0264 | .0312 | .0396 | .0432 | .0206 | .0245 | .0396 | .0462 | .0773 | .0808 | .0396 | .0417 | .0591 | .0641 |
| F $\times 10^5$ | 3.8531 | 3.925 | 5.4987 | 5.604 | 3.8531 | 3.984 | 5.4987 | 5.613 | 8.8901 | 8.941 | 5.4007 | 5.681 | 9.6777 | 9.774 |

J3 is the index of the controlled maximum shear of the ground level columns divided by maximized peak base shear of the building, J4 is the representative of the maximized norm of based inter-story drift, J5 is the norm of based floor acceleration for RMS of stochastic components of controlled output vector, J6 is the indicator of the maximized norm of base shear of the structure, J7 is relate to the control device evaluation criteria i.e. maximized peak control force criteria, J8 is the maximized peak control device stroke relative to floors which is installed, J9 is the indices of maximized peak control power of actuators, Y is the maximum stroke (relative displacement of actuator's piston with frame) in each corresponding earthquake as mentioned above, F is the maximum optimal required control force of actuators applied to reduce the response of the structure. The Bold-Italic written number of above results are relate to sliding mode control approach of control strategy. As seen in table 1, the J-indices relate to controlled response quantities (i.e. J1~J6) in LQG method, are greater than of SMC approach. This fact

narrates that SMC approach can appropriately control the response of the structure specially, in presence of severe excitation and large uncertainty in dynamic characteristics of the structure. On other hand, it could be serves a much little control efforts such as energy and cost to at SMC in comparison to LQG method. That is the control performances related to control forces and actuator's strokes (i.e. J7~J9,Y,F) indicate that the a few much control efforts were been spent in SMC approach with respect to LQG method.

5. Conclusions

Intensive numerical simulation analyses have been performed for active control of three seismically seismic excited mid to high rise structural models. We use the comprehensive full-order and reduced order model of evaluation and measurement control, output, and sensors state-space representation to handle the complete features of control analysis of the structure. In design of

controller, we implement two approach of modern control design, i.e. LQG and SMC which are the stochastic optimal control methods. To find the immeasurable states, we use from optimal observer gain in the sense of Kalman Filter to estimate these necessary measurement feedback states. To deal with both uncertainty in dynamic characteristics of model structures and fluctuations of unpredictable imperfection in severe intensified seismic excitation records, we design the robust control force for actuators with implemented suitable sliding margin to robust and secure control of structures. According to the literature on optimal stochastic design of compensators[13], The number of arrays of dominate state vectors needed for obtaining the control gains, should be selected at least one half of the length of observable reduced state vectors of control plants,[14]. In this way, and using intensive trial and error, it was practically concluded that the selection of one third of that results in better convergence and noise reduction in our control model. There exists a limitation in stochastic design of filters for un-measurable feedback states in the reduced control plant. The number of dominant states here is 18-24 in the reduced model and the mathematical assumption for considering the Gaussian distribution for noisy states is not fully correlated with the nature of dynamic behavior of structure. Therefore selection of more than 6 states in stochastic predictor does not fulfill the error convergence. Some noticeable results which clearly shown from simulation are:

- Application of SMC procedure in case of severely intensified seismic excitation and in presence of large margin of uncertainty of stiffness matrix of structure is very efficient to robust control and stabilizing the controlled response of model structures.

- In both control routines, the number of states which combined with discrete compensators should not be greater than one-third of sum of the order of reduced evaluation state-space model, because of good approximation to estimating of optimal observer design.

- The number of noisy measured feedback states which modeled as band-limited filtered passed random generation process, should not be greater than 4~6 vector components because of the sensible error/noise rejected to the control compensator and occurred the defeat to design of controllers.

- In spite of good advantages of using the SMC in reduction of control responses of structure in compared to LQG, the LQG procedure is a little cheaper than SMC in control cost of design of the ATMD.

- As seen deliberately in controlled response results, we can conclude that the efficiency of SMC approach compared to LQG is about 9~16 percent in reduction of structural responses and on the other hand, the efficiency of LQG compared to SMC method is approximately 12~21 percent in energy saving purposes and affording investigations.

6. References

- [1] Ohtori, Y., Christenson, R. E., Spencer, B. F., Jr., and Dyke, S. J. (2004), "Benchmark control problems for seismically excited nonlinear buildings", *J. Eng. Mech.*, 130(4), 366-385.
- [2] Yang, J. N., Wu, J.C., Agrawal, A. K., and Hsu, S. Y. (1997), "Sliding mode control with compensator for wind and seismic response control", *Earthquake*

- Engineering and structural dynamics, Vol. 26, 1137-1156.
- [3] Tewari, A. (2002), "Modern control design with MATLAB and SIMULINK", John Wiley & Sons.
- [4] Caughey, T. K. (2001), "Practical applications of active and semi-active structural control systems to actual civil engineering structures. ", Earthquake Eng. Struct. Dyn., 30(11), 1697-1717.
- [5] MathWorks, Inc., (2000), "Robust control Toolbox for use with MATLAB", User's Guide., Natick, MA.
- [6] Spencer, B. F., Dyke, S. J., and Deoskar, H. S. (1998). "Benchmark problems in structural control. I: Active mass driver system, and II: Active tendon system". Earthquake Eng. Struct. Dyn., 27(11), 1127-1147.
- [7] Somanathan Nair, B. "Digital Signal Processing, Theory, Analysis and Digital-Filter Design", published by Prentice-Hall, of India, New Delhi, (2006).
- [8] Yang, J. N., Wu, J. C., Reinhorn, A. M., and Riley, M. (1996a). "Control of sliding-isolated buildings using sliding-mode control.", J. Struct. Eng., 122(12), 179-186.
- [9] Utkin, V. I. (1992). "Sliding modes in control optimization", Springer, Berlin.
- [10] M. Aldawod, B.Samali , F. Naghdy, K.,C.S.Kwok, "Active control of along wind response of tall building using a fuzzy controller" , Engineering Structures 23 (2001) 1512-1522.
- [11] Franklin, Gene F. Powell, J. David. Emami-Naeini, A. "Feedback Control of Dynamic Systems". Fourth Edition, Pearson Education, Published by Dorling Kindersley (India) Pvt. Ltd (2006).
- [12] Amini, F., Vahdani, R., Rahemi, B. (2005), "Semi-active control of variable stiffness and damping systems by pole-assignment method", Computational methods and experimental measurements, XII 465, Vol. 41, WIT Press.
- [13] Dukkupati, Rao V. "Analysis and Design of Control Systems using MATLAB", New Age International Publishers (India), (2006).
- [14] Tao, Gang. " Adaptive Control Design and Analysis", Wiley series on adaptive and learning systems for signal processing, Communications, and control, Simon Haykin, Series editor, Published by John Wiley & Sons, Inc, (2003).