

Study on optimized piled-raft foundations (PRF) performance with connected and non-connected piles- three case histories

A. Eslami^{1,*}, M. Veiskarami², M. M. Eslami³

Received: June 2010, Revised: October 2010, Accepted: March 2011

Abstract

It has been realized that the raft (mat) foundations are capable of bearing very large loads when they are assisted with a pile group. The contribution of both raft and piles to carry the surcharge loads is taken into account, considering the stiffness and strength of involved elements in the system, i.e. piles, raft and surrounding soil. The piles are usually required not to ensure the overall stability of the foundation but to act as settlement reducers. There is an alternative design in which, the piles are non-connected from the raft to reduce the settlement, which are then known to be "settlement reducer non-connected piles" to increase the system stiffness. In this paper, two and three dimensional finite element analysis of connected and non-connected pile-raft systems are performed on three case studies including a 12-storey residential building in Iran, a 39-storey twin towers in Indonesia, and the Messeturm tower, 256m high, in Frankfurt, Germany. The analyses include the investigation of the effect of different parameters, e.g. piles spacing, embedment length, piling configuration and raft thickness to optimize the design. The role of each parameter is also investigated. The parametric study results and comparison to a few field measurements indicate that by concentrating the piles in the central area of the raft foundation the optimum design with the minimum total length of piles is achieved, which is considered as control parameter for optimum design. This can be considered as a criterion for project cost efficiency. On the other hand, non-connected piled-raft systems can significantly reduce the settlements and raft internal bending moments by increasing the subsoil stratum stiffness. Finally, the comparison indicates that simple and faster 2D analysis has almost similar results to the time consuming and complicated 3D analysis.

Keywords: Piled-raft foundations (PRF), Optimized design, Connected piles, Non-connected piles, Finite element analysis

1. Introduction

Pile groups are conventionally designed by adopting a relatively high factor of safety to the piles and the major design criterion is the bearing capacity of the group. The arrangement of these piles in the group is to carry the entire load of the superstructure. Although the connection "cap" often a raft (or mat) is in close contact with the soil, its contribution to the total bearing capacity and general pile group behavior is seldom considered in analysis and design [1].

One of the most effective ways for increasing the bearing capacity of a foundation has been experienced to be the pile enhancement. The system is known as hybrid foundation or

piled-raft foundation (PRF) [2,3]. The piled-raft foundation is a recent design concept as one of the effective methods of foundation to reduce settlements of structures [4]. In piled-raft systems, the design procedure differs from traditional foundation design, in which the loads are assumed to be carried either by the raft or by the piles, considering the safety factor in each case. In the design of piled rafts the load sharing between the piles and the raft is taken into account, and the piles are used up to a load level that can be the same order of magnitude as the bearing capacity of a comparable single pile or even greater [2,3].

Therefore, the piled raft foundation allows reduction of settlements and differential settlements in a very economic way compared to traditional foundation concepts. In recent development of piled raft foundation design, the piles are usually required not to ensure the overall stability of the foundation but to act as settlement reducers. The raft in this system has adequate bearing capacity and therefore, the main objective of introducing these pile elements is to control or minimize the average and/or differential displacements of the

* Corresponding Author: afeslami@aut.ac.ir

1 Associate Professor, Amir Kabir University of Technology (AUT), Tehran, Iran

2 Assistant Professor, University of Guilan, Rasht, Iran

3 M.Sc. Student, Sharif University of Technology, International Campus, Kish Island, Iran

piled raft system, rather than to carry the major portion of the loads [5,6]. Figure 1, shows the effect of pile reinforcement beneath a mat foundation. It is clear that the reduction in general settlement is significant for piled-raft foundation [7].

Practically, the pile head is structurally connected with, or penetrated into, the raft to form a rigid connection. In conventional piled raft design, the number of piles is normally great and the load carried by each individual pile is relatively miniature. There is a high safety margin before the piles reach their geotechnical bearing capacity or structural failure load. The capacity of the piles is generally governed by geotechnical considerations rather than by the compressive strength of the pile material. In addition, the resistance of piles to horizontal forces through suitably designed connections is usually adequate due to the large number of piles used. When settlement-reducing piles are designed as structural components, a low factor of safety can be applied to the geotechnical capacity of the piles and the raft alone is adequate [2,5]. However, when these piles are structurally connected to the raft, as they are in traditional construction, a high axial stress may develop in the relatively small number of piles. Thus, the load-carrying capacity of these settlement-reducing piles may be governed by their structural capacity rather than by geotechnical capacity. In addition, these sparsely arranged structural piles beneath a raft may not provide adequate horizontal resistance to lateral loads. One alternative in the design of these piles is to consider them as stiffeners for the base soil so that the above-mentioned problems would be avoided [8].

In this research, an alternative design concept for settlement-reducing piles by disassociating the piles from the raft is examined. By employing three building case histories it has been tried to optimize the foundations with using connected and non-connected (sometimes called "disconnected") piles and by changing the number of piles, their positions and raft thickness. Thus, this work can be considered as a new approach to the analysis of pile-enhanced mat foundations. The privilege of using a simplified linear finite element model over complicated nonlinear models has been implicitly studied with comparison of the predicted and measured data. Such simplified modeling seems to be adequate for comparison and preliminary design purposes. It should be noted that although the lateral bearing capacity of foundations enhanced by non-connected piles are not controlled by the piles, which can be a disadvantage for such

systems, in foundations with connected piles this lateral resistance is not significant in comparison to the load carrying capacity of piles under vertical loads and their role in reducing the settlement. This shortcoming can be balanced by base adhesion and cohesion, shear keys and base embedment depth. This study is focused on the vertical bearing capacity and settlement of piled-raft systems and discussions on horizontal behavior requires a deep study which is not aimed here.

2. Numerical Modeling

To date, the analyses of piles and piled raft using finite elements method are done in an excellent manner by many authors [7,9-12]. The Finite Elements Method (FEM) has been known as a versatile and powerful tool in analysis of piled-raft foundations. Based on this method, PLAXIS code is one of the most common software in modeling, analysis and design of shallow and deep foundations. In this code, formulation of the deformation theory is taken into account to provide the capability of analysis of elastic and elasto-plastic systems consisting of different element types, e.g., plane-strain 2D elements together with plate bending elements which are widely used in modeling of shallow and deep foundations [13]. The details of computational procedure have been presented in the appendix of this paper.

In the recent years, application of the finite elements method in analysis of piled-raft foundations has been more considered. Hassen and de Buhan (2005) used a 2D finite elements analysis for analysis of a mat foundation with and without pile enhancement. They have developed a finite elements code which performed the analysis of piled-raft foundations in the context of elasticity with extension to the elasto-plasticity with an iterative procedure. They also studied the effect of bending and shear stiffness neglecting in analysis [7]. Seo *et al.* (2006), has presented a numerical model of piled-raft foundation in sand [4].

Very recently, Noh *et al.* (2008) presented the results of the finite elements based analyses of a series of different size mat foundations with and without pile group beneath, in sandy soils of Surfers Paradise of Australia. PLAXIS code was employed to achieve the results. They have studied the effect of raft thickness and number and spacing of piles on the internal shear forces and bending moments. Figure 2, shows the general outlines of the 2D model and a summary of the results [10]. A successful attempt of the numerical modeling compared with experimental data has been made by Baziar *et al.* (2009). They showed that although the system is highly complex, but the overall behavior of the composite system of pile-raft foundation obeys a linear trend when the loads are below working loads as shown in Figure 3 [12]. Therefore, it can be concluded that a linear elastic system can be approximated for a pile-raft foundation when the loads do not exceed the working loads.

Any theoretical model for analyzing piled raft should consider the complex interactions among piles, raft and soil. Therefore, plane strain and axi-symmetric finite element models can be used for this purpose. However, the plane strain model involves the fundamental simplification of condensing a finite size piled raft ratio into a strip piled raft. Desai *et al.* (1974) showed that this type of model can provide good results

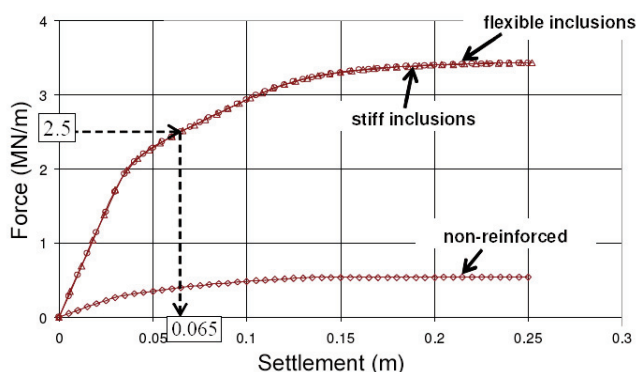

Fig. 1. Effect of pile enhancement on the bearing capacity of a foundation system, a) Without pile enhancement and b) with pile group enhancement [7]

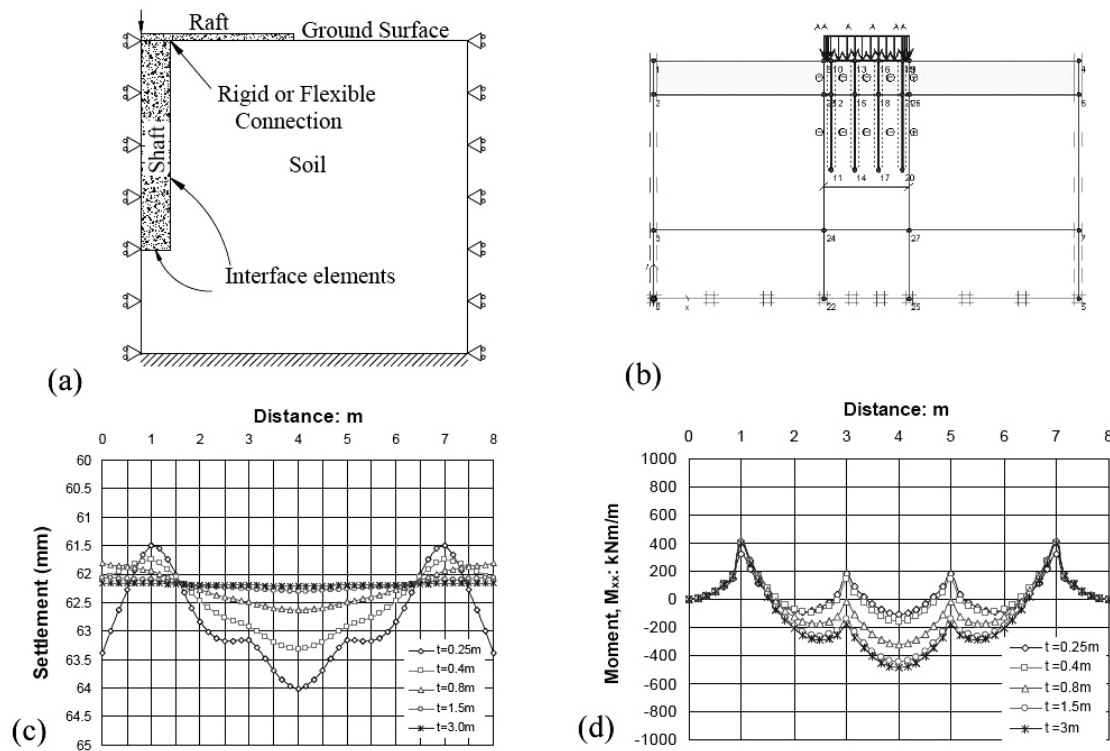

Fig. 2. Modeling of a piled-raft foundation, a) general modeling of pile and boundary conditions, b) PLAXIS modeling of a piled-raft foundation, c) effect of foundation thickness on the generated deformation and d) effect of foundation thickness on the internal moments [10]

[14]. The piles are simplified into strips with equivalent pile young's modulus, E_{eqps} , given by Prakosa and Kulhawy (2001) as denoted by Eq.1 [1]:

$$E_{eqps} = \frac{n_{p-row} A_p E_p}{L_r B} \quad (1)$$

In this equation n_{p-row} is number of piles in row i , A_p is area of pile cross section, E_p is pile young's modulus, L is raft length (in plane) and B is pile diameter.

For axi-symmetric models, using Eq.1, the piles are simplified into rings with equivalent pile young's modulus, E_{eqr} that can be proposed by Eq. 2, as follows:

$$E_{eqr} = \frac{n_{ring-i} A_p E_p}{2\pi R_i B} \quad (2)$$

In this equation n_{ring-i} is number of piles in row i , R_i is radius of the i^{th} ring.

For elasto-plastic models, a further simplification is required because the equivalent plane strain and axi-symmetric piles should have the same compression capacity (toe and shaft resistances) as represent the capacity of the in-plane row of piles and ring piles. Plane strain and ring piles have two sides, the equivalent side shear resistance for interface element at a given depth on each side for plane strain model, f_{s-egp} , is given by Prakosa and Kulhawy (2001) as illustrated in Eq.3 [1]:

$$f_{s-egp} = \frac{n_{p-row} A_s f_s}{2L_r} \quad (3)$$

Also for axi-symmetric piles it can be represented by Eq.4:

$$f_{s-ega} = \frac{n_{ring-i} A_s f_s}{4\pi R_i} \quad (4)$$

In this equation, A_s is the surface area of pile per unit depth and f_s is side shear resistance of pile per unit depth.

No further modification was carried out for pile toe resistance. PLAXIS is used in 2D modeling. The three-dimensional (3D) analysis is performed by the aid of a similar 3D computer code, i.e., PLAXIS 3D FOUNDATION. The finite elements method is adopted for analysis of three case studies of piled-raft foundations by the aid of these computer codes.

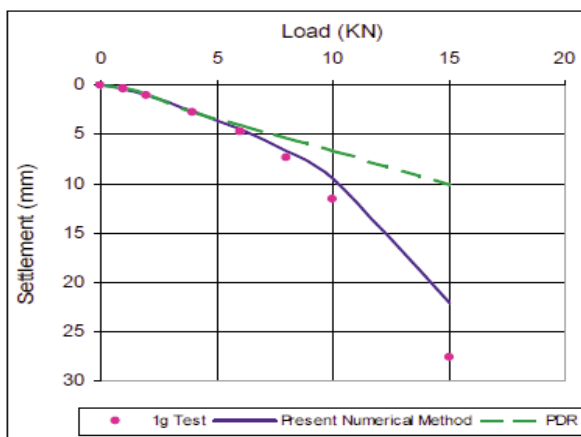

Fig. 3. Load-settlement curve from measurements and numerical modeling showing a linear trend for loads lower than working load [12]

3. Optimum Design of Piled-Raft Foundations

In the current design method for piled rafts, the bearing capacity of the raft is always neglected. The piles are assumed to take all the imposed loads, and the overall factor of safety of the foundation is based only on the pile capacity. However, the raft can contribute significantly to the overall foundation capacity; Cooke (1986), for example, has reported that up to 30% of the building loads could be carried by the raft [15]. Regarding the investigation of a couple of piled raft foundations behavior around the world by Hemsley (2000), a contribution of 50% load sharing between the raft and the piles have been experimented. The overall safety factors adopted in the current design of piled rafts may, therefore, be excessively high [16].

Wong *et al.*, (2004) proposed the introduction of a small group of piles beneath the central area of a flexible raft to reduce maximum and differential settlements [8]. These piles are usually structurally connected to the raft, although consideration of structural capacity for settlement-reducing piles can be critical due to the relatively high axial stress that may develop in the piles. Therefore, the use of these piles may be limited if they are designed as structural members. Generally, wind and earthquake loads imposed on the superstructure are the main horizontal forces that are transmitted to the pile heads in the foundation system [8].

The required cross-sectional area of piles can be determined by checking for bending and shear resistance of the pile heads. In order to resist possible high earthquake and wind loads, a large total section area of piles is required, which can be obtained with either a large number of piles or a smaller number of piles having larger section areas. However, for the design of raft foundations with settlement-reducing piles, an increase in the pile number or the use of larger piles just to enhance the horizontal load capacity may not be economically justifiable. Although the adhesion force along the interface between soil and raft and the passive pressure of substructure are the main source of resistance to horizontal loads. This consideration may therefore restrict the use of settlement-reducing piles.

Hemsley (2000), in a review of piled raft foundations, observed a reduction of settlement if the base soil beneath the raft was considered as a reinforced elastic medium. One alternative method of foundation design is therefore to introduce piles purely as a means of improving or enhancing the stiffness of the base soil by structurally disconnecting the piles from the raft. A gap can be provided between the piles and the raft such that the piles would not directly carry the loads from the superstructure. Once these settlement-reducing piles are no longer structurally connected to the raft, a much lower factor of safety against structural failure than that suggested for structural piles can be used without violation of most building codes [16].

Since the geotechnical capacity of non-connected piles can be assumed to be fully mobilized, the structural considerations of such settlement-reducing piles are no longer critical in the design. Small differences and uncertainties in loads and material strengths may be ignored because these piles will not act as the main load-carrying members. Even some small cracks in the piles may not significantly reduce their role of

reinforcing the base soil.

Thus these non-connected settlement-reducing piles may be allowed to carry much higher loads than structurally connected piles, with resulting economic benefits [16].

Furthermore, possible damage to structural connections is no longer a design issue, and the horizontal loads can be effectively transmitted through the mobilized adhesion force along the soil-raft interface. In addition, as the construction of raft foundations for high-rise buildings usually incorporates a basement, the horizontal forces may also be resisted by passive pressures acting on the basement walls.

To optimize the design parameters of piled-raft foundations, these functions such as; minimum uniform and non-uniform settlements, internal moments and shear forces, etc., decreasing of foundation thickness, minimizing the number of piles and their embedment length and also pile group geometry is implemented.

Cao *et al.* (2004) performed a series of experimental tests on piled-raft foundations to investigate the effect of piles different geometrical parameters on abovementioned design parameters. They observed that the increase in raft thickness has a little effect on maximum settlement, however, a significant effect on differential settlement and internal moments. Also, outcome demonstrated the pile embedment length extending has a great consequence on maximum settlement, but its effect on internal moments is negligible. It was also noticed that the effect of pile length on differential settlement depends on applied load intensity, i.e., in higher load intensities, application of longer piles results in a differential settlement reduction. Moreover, the influence of total number of piles in pile group is significant for higher load intensities, but its effect on internal moments is negligible [17].

There are a number of factors that affects the analysis and design of unsupported mats and piled-raft foundations that have been presented in the literature [16,18].

4. Case Histories: Records and Results

Three case histories have been used for performing two and three-dimensional analysis of buildings raft foundations enhanced with connected and/or non-connected piles group. A summary of records and results for each case is presented in the following.

Case 1: Afsoon Coastal Building

Afsoon, a 12-storey coastal building is located in Babolsar, near shoreline of the Caspian Sea in northern Iran. The dimensions of the mat foundation in plan are 25m×25m. A total vertical dead load of 53.28MN is expected to be carried by the combined foundation. Subsoil layers consist of coastal sand, blown sand and some silty sands in the deep layers. SPT blowcounts, in the depth, with an average of 18, show a loose to medium subsoil condition down to 22.0m below ground level. Dense to very dense layers (SPT blowcounts greater than 45) is located below 22.0m depth. Elasticity coefficient, poisson's ratio and soil internal friction angle are 35MPa, 0.3 and 30° respectively for subsoil layers. (Report-No. 83) [19].

A composition of driven piles and a mat foundation is

employed to resist the liquefaction and control further settlements. 23 driven piles with a circular section and an average length of 8.5m and 19 vibro-driving H-piles with average length equal to 10.0m were penetrated into the ground to improve subsoil properties. The mat thickness is 0.8m and embedded in -1.5m elevation below the ground level. The piling pattern is shown in Figure 4.

A site monitoring and surveying program was performed to measure the average settlement of the foundation system. The maximum settlement of about 26.0mm is obtained. Also two and three-dimensional finite element modeling of this project is shown in Figure 5a and 5b. The results demonstrate that a 19.0mm average settlement can be considered for the foundation which shows a good agreement with measured data. This value has been obtained by the simplified equivalent elastic analysis instead of a highly complicated nonlinear FE analysis. The maximum settlement from two and three-dimensional analyses were obtained to be 26.8mm and 23.3mm consequently. The element properties are presented in Table 1.

Case 2: High-Rise Building in Jakarta, Indonesia

A parametric study based on plane strain finite element method has been applied to a raft foundation proposed for a high-rise building in Jakarta, Indonesia, to explore the feasibility of the design philosophy involving the use of non-connected settlement-reducing piles [16].

The proposed building is a 39-storey twin-tower structure supported on a rectangular raft 44.0m×99.0m with a 2-storey

Table 1. Mechanical properties of elements in 2D-FE analysis for Afsoon building, Babolsar, Iran

Mechanical Properties	Raft	Double-Pile Model	Four Piles Model
EA (kN/m)	20000000	218551.13	437102.26
EI (kNm ² /m)	1066666.6	2231.04	4462.08

basement. Soil properties of Jakarta dates back to Holocene era consist mainly of layers of medium to stiff clay. In corresponding foundation analyses, the raft is assumed to rest directly on the surface of a 86m thick stiff clay stratum which is underlain by a rough rigid base. The clay is assumed to have an average undrained Young's modulus of 178MPa and a Poisson's ratio of 0.49. The clay stratum is assumed to behave as an undrained material during loading. The undrained shear strength (S_u) of the clay is taken to be 240kPa. The young's modulus of the concrete is 40 MPa. The poisson's ratio of concrete is 0.15. The rafts are 2.0, 3.65, 5.0m thick and 44m wide. The bored piles are 1.0m in diameter and 25.0, 35.0, 45.0, 65m in embedment depth.

Two sets of analysis are performed on this case. The first set was aimed to compare the results between the connection and separation of piles and mat foundation. This is a comparative analysis for 35m and 65m long piles under foundation. The results were then compared with the results presented by Randolph (1983) on this foundation [20]. In the second set of analysis, which is a parametric study, the effect of different elements, e.g., foundation thickness, piles length and pile group arrangement have been studied. In the latter analysis, the total length of piles was held constant. In both set of analyses a plane strain analysis has been performed. Since the non-connected piles are not expected to carry lateral and moment forces and employed to improve soil stiffness and decrease its deformability behavior, a one-dimensional beam element with an axial stiffness only, has been employed to model a non-connected pile under a mat foundation. However, the piles were modeled with plate elements including axial and bending stiffness that corresponding to a real pile behavior beneath a foundation. The mat foundation is also modeled with plate element. An elasto-plastic Mohr-Coulomb soil model according to the soil geotechnical and geomechanical properties was assumed for subsoil layers.

Figure 6 shows the cross-section of the pile arrangement used in the analysis. For the non-connected piles, a soil gap of 1.0m thickness is assumed to exist between the pile heads and the raft. Four rows of identical piles are placed symmetrically

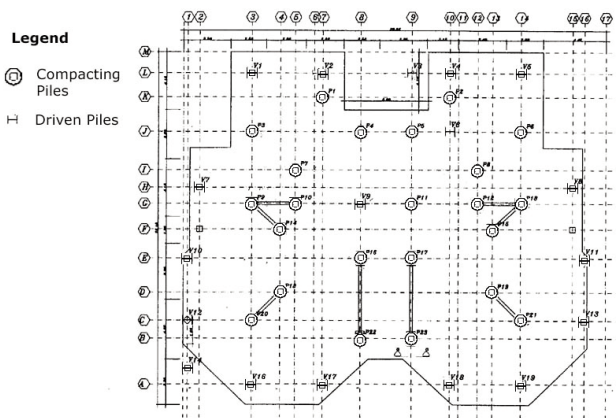

Fig.4. Afsoon coastal building foundation plan and pile arrangement

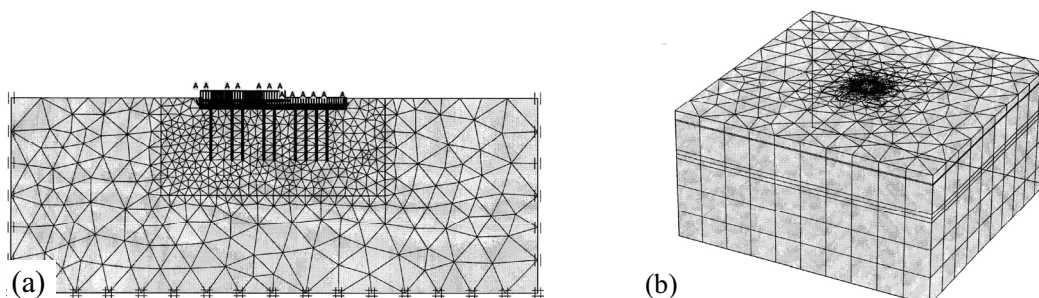

Fig.5. Afsoon coastal building FEM modeling a) 2-dimensional model and b) 3-dimensional model

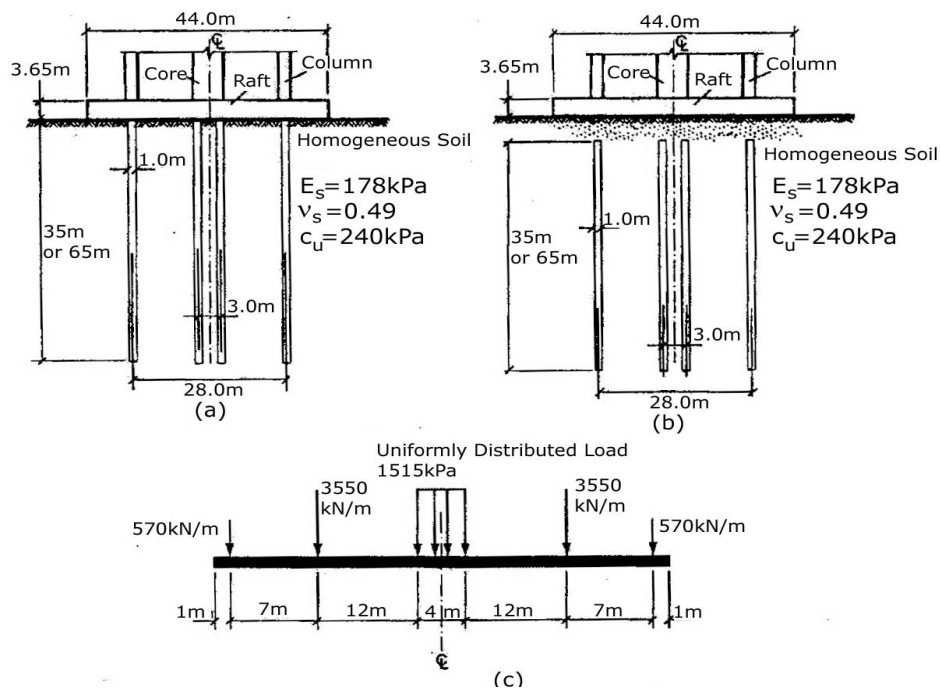

Fig. 6. Foundations characteristics for high-rise building in Jakarta, Indonesia a) connected piles, b) non-connected piles and

about the centerline of the raft. The two interior rows of piles are directly beneath the central core area of the building, and the two outer rows are placed where the heavier concentrated line loads are located. In each row of piles, the pile spacing is 3.0m. Elements properties are presented in Table 2.

Figure 7 shows the results of the first set of analyses. A good correlation can be observed between the obtained results and the results that were presented by Randolph (1983) [20]. These consequences show that by increasing the pile length from 35m to 65m, internal moments, maximum and differential settlements of the raft decreases significantly. Another important result is that connecting the piles to the raft or not, has no significant effect on deflections and internal forces and moments diagrams. This is also remarkable that in case of non-connected piles, the pile axial load decreases. In this case, all piles are required to control the settlement while the raft provides the bearing capacity. Thus, by decreasing the axial loads on piles, the role of piles, will be changed to settlement reducing elements. In fact, unlike connected piles, in piled-raft foundations with non-connected piles, the piles have less contribution in load carrying system. Therefore, their structural factor of safety will increase.

A parametric study has been performed in which, different design alternatives have been considered in comparison with the original values. In these analyzed cases, the external loads and some geometric parameters were kept constant and

Table 2. Mechanical properties of elements 2D-FE analysis for high-rise building, Jakarta

Mechanical Properties	Raft	Pile Model
EA (kN/m)	54000000	7074000
EI (kNm ² /m)	18000000	589500

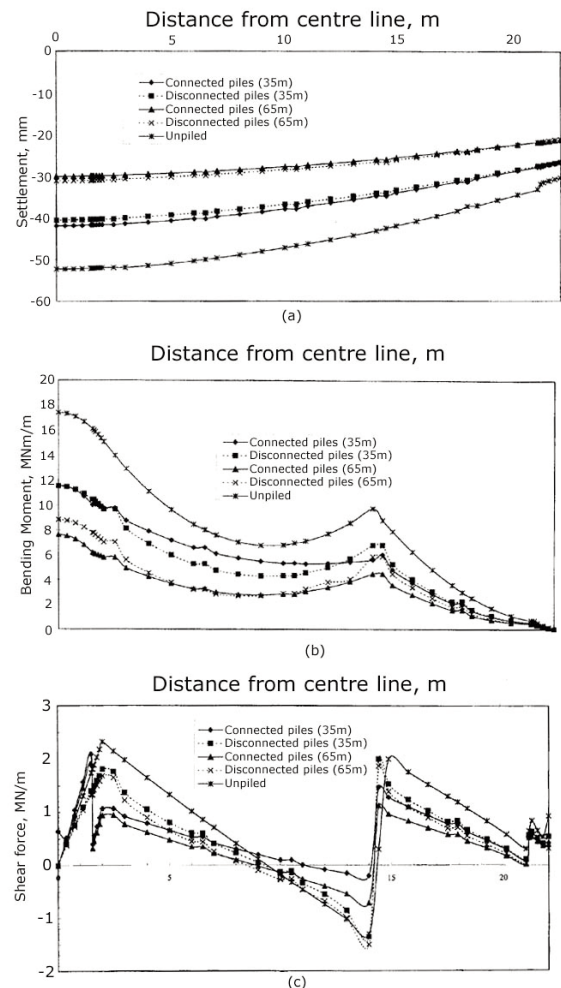

Fig. 7. Results of modeling of high-rise building in Jakarta, Indonesia, a) settlement, b) bending moment in the raft c) shear forces in the raft

sensitivity of the system to the remaining parameter(s) has been investigated. In parametric analyses the following variations have been included:

- Pile length: The original length of 35m was kept as reference value while shorter piles, 25m long, and longer piles, 45m long, were analyzed.
- Raft thickness: The reference value was kept 3.65m with raft thicknesses of 2 and 5m.
- Piles configuration: The configuration was related to the length of the piles and their position. Six distinct configurations were analyzed including the raft only (without pile enhancement) and five pile-enhanced raft cases in which the lengths and pile arrangements have been changed as shown in Figure 8.

Therefore, 17 distinct parametric design alternatives were compared and analyzed against the values of reference design solution. As illustrated in Figure 9, based on all parametric studies the following outputs have been drawn:

- Increase in the raft thickness has a little effect on the maximum achieved settlement; however, its effect on the differential settlement and internal moments is valuable. For example, increasing the raft thickness from 2.0m to 5.0m decreases the differential settlement up to 50%, but increases the internal moments up to 100% to 150%. In most cases, more shear forces were developed with increasing the raft thickness
- Change in the pile location from the exterior ring (edges) to the middle region of the raft results in a settlement reduction.

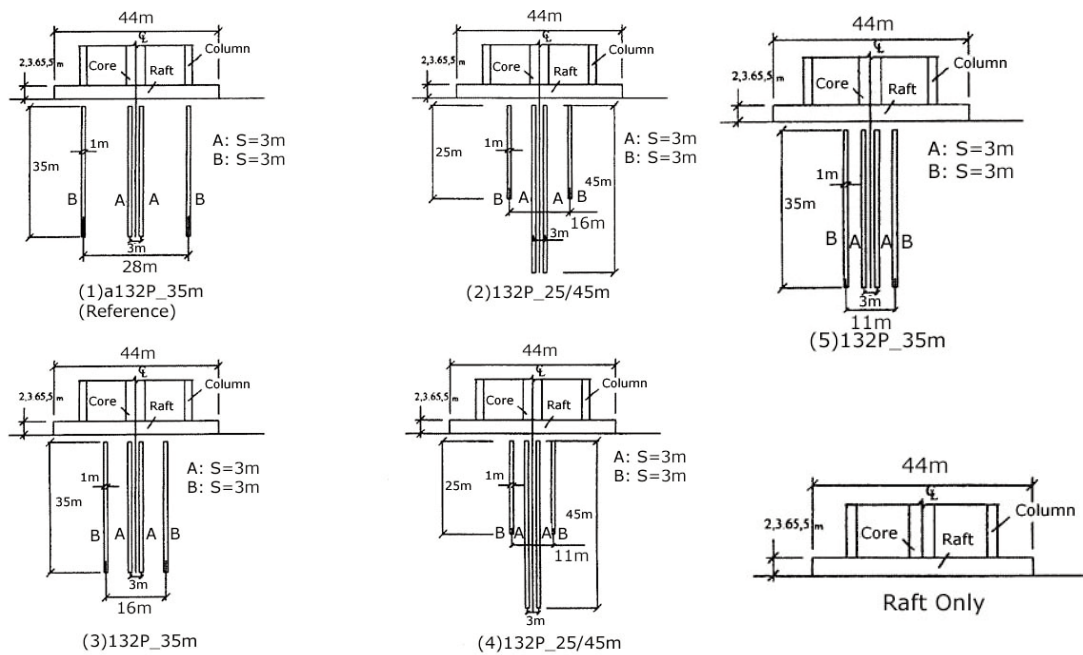

Fig. 8. Different models of high-rise building in Jakarta, Indonesia

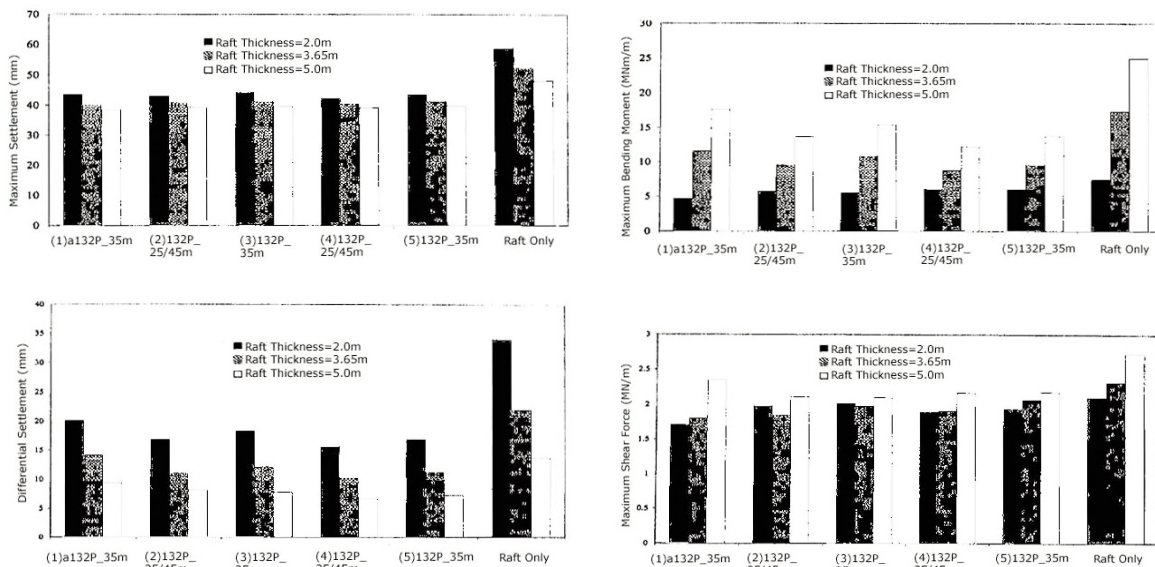

Fig. 9. Comparison of the analysis results for different systems used for high-rise building in Jakarta, Indonesia

If one takes B_g as the width of the raft which is enhanced with pile and B as the total width of the raft, for cases 1, 3 and 5 in Figure 8 and Figure 9, the ratio of B_g/B is 0.63, 0.36 and 0.25 respectively and the corresponding differential settlements are 20.2, 18.4 and 16.9mm for a raft thickness of 2.0m. Also for a constant value of B_g/B ratio and raft thickness, e.g., $B_g/B=0.25$ and raft thickness of 2.0m, decreasing the length of outer piles and increasing the length of inner piles, the maximum settlement reduces from 16.9mm in case 5 to 15.6mm in case 4. Thus, by using both approaches, i.e., reducing B_g/B ratio while increasing piles lengths and decreasing outside piles length, a reduction in maximum raft settlement from 20.2mm to 15.9mm is obtained. In this case, the total length of piles and raft thickness were not changed and the only variable was the arrangement and the length of individual piles in middle and side regions.

- By varying the pile location from the outer zones to the middle, for B_g/B ratios equal to 0.63, 0.36 and 0.25 in cases 1, 3 and 5 correspondingly, the maximum internal moment for a raft thickness of 5.0m is equal to 17.62, 15.46 and 13.81MNm/m respectively. Also for B_g/B ratio equal to 0.25 and raft thickness equal to 5.0m, by increasing the length of the middle piles and decreasing the pile lengths located in the exterior zones, the maximum internal moment was reduced from 13.81MNm/m for case 5, to 12.23MNm/m for case 4. Again, for a certain raft thickness equal to 5.0m, the maximum internal moment can be reduced from 17.62MNm/m to 12.23MNm/m by changing the arrangement and length of each pile in the pile group, while their total length is held constant. It is notable that for rafts with less thickness under higher loads, the aforementioned results may be violated.

- Arrangement and length of individual piles has no significant effect on internal shear forces.

- Although any increase in the raft thickness reduces the differential settlement, it increases the internal moments and shear forces. Thus, an optimum design must be achieved by

selecting an optimum raft thickness that reduces the quantity of construction materials together with an increase in the maximum differential settlement toleration limits.

- It is clearly observed that the application of the minimum number of piles to reduce the foundation settlement has significant effect on the reduction of internal moments and shear forces in comparison with an individual raft foundation.

- Original design approach in practice was case 1 (No. (1)132P_35m) in Figure 9 that is based on the minimum number of piles for settlement reduction. However, on performing some changes to optimize the configuration, case (4)132P_25/45m, shown in Figure 8, was designated as the optimum case in which the arrangement and length of individual piles in pile group were optimized.

Case 3: Messeturm Building, Frankfurt, Germany

The piled raft of the 256m high Messeturm comprises 64 bored piles and a square raft with an edge length of 58.8m. The length of the piles ($D_p=1.3$ m) varies from 26.9 m (outer ring) through 30.9 m (middle ring) to 34.9 m (inner ring). The foundation level of the 3.0 to 6.0m thick raft lies 11.0 to 14.0m below the ground level shown in Figure 10. The subsoil condition in Frankfurt is characterized mainly by Tertiary soils and rock. They consist of Frankfurt clay at the top underlain by the rocky Frankfurt clay in depth. The effective load intensity applied on foundation that is the difference between the total applied load on the foundation level and uplift load, is equal to 1568.6MN [16,21,22].

Since the arrangement of piles in the pile group is close to a circular arrangement, an axisymmetric finite element model is adopted to this case. The maximum and differential settlements are calculated to be 160.3mm and 50.5mm respectively that show a good agreement with the site measurements which were 144.0mm and 60.0mm correspondingly [22].

A parametric study by making use of PLAXIS and PLAXIS 3D FOUNDATION has been applied to the Messeturm

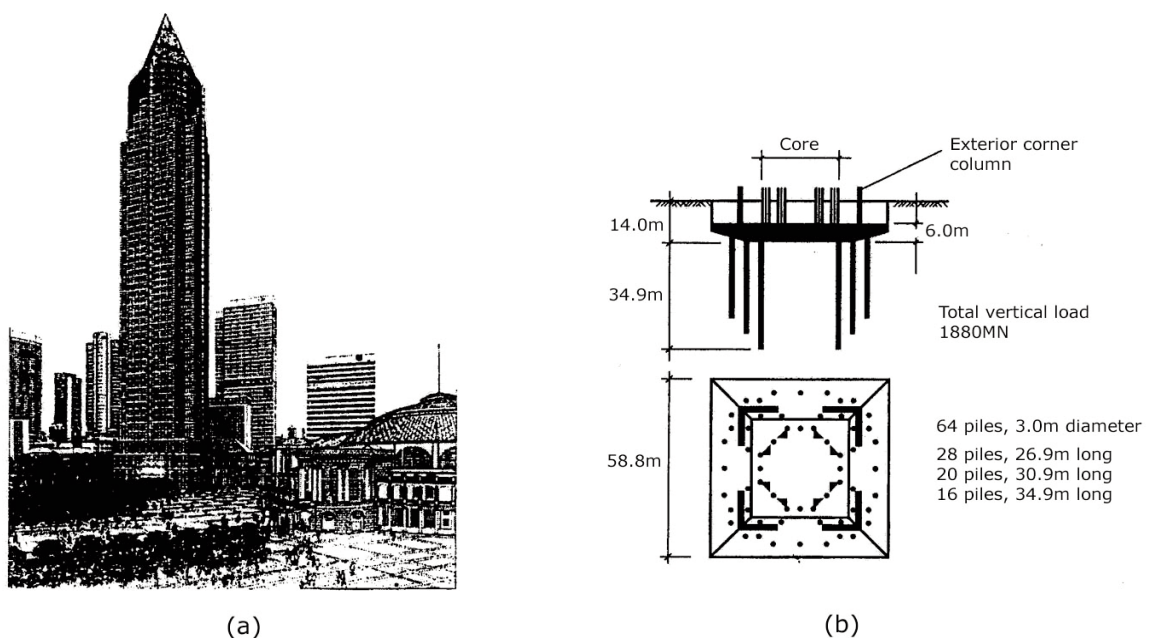

Fig. 10. Messeturm building in Frankfurt, Germany, a) side view, b) sketch of foundation system

building (Figure 11) considering different pile configurations. In this study some variables were kept constant, e.g., column load, subsoil conditions and raft thickness. However, others were varied, e.g. the position, the embedment length of piles and the total length of piles which are illustrated in Figure 12.

Again, plate elements were employed to model the mat foundation and piles in both two and three dimensional analyses as illustrated in Figure 13. Elements properties are presented in Table 3.

In the parametric study the following variations were adopted:

- Young's modulus of soil was kept constant with depth, equal to 60MPa.
- Pile length: Included 35.0, 31.0 and 27.0m length.

- Total length of piles: This parameter was varied in each configuration.

- Piles arrangement: It was related to the length of the piles and their positions. Seven distinct configurations were considered.

The main assumption is that piles are not in contact with the mat foundation.

The following points regarding the comparison of different functions as illustrated in Figure 12 can be observed.

- In the original (reference) alternative, most of the piles are located at further distance from the middle raft region. However, concentration of piles in the inner region leads to a decrease in the settlement. Owing to the concentration of piles in the inner part of the raft it can also be observed that by

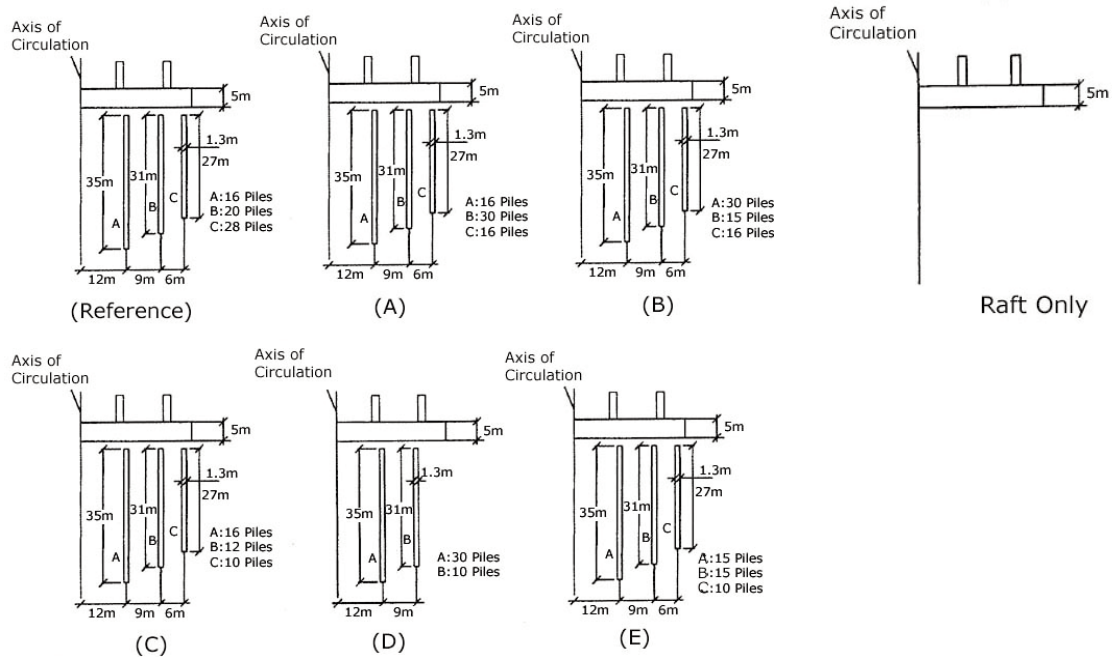

Fig. 11. Different foundation configuration systems of messeturm building in Frankfurt, Germany

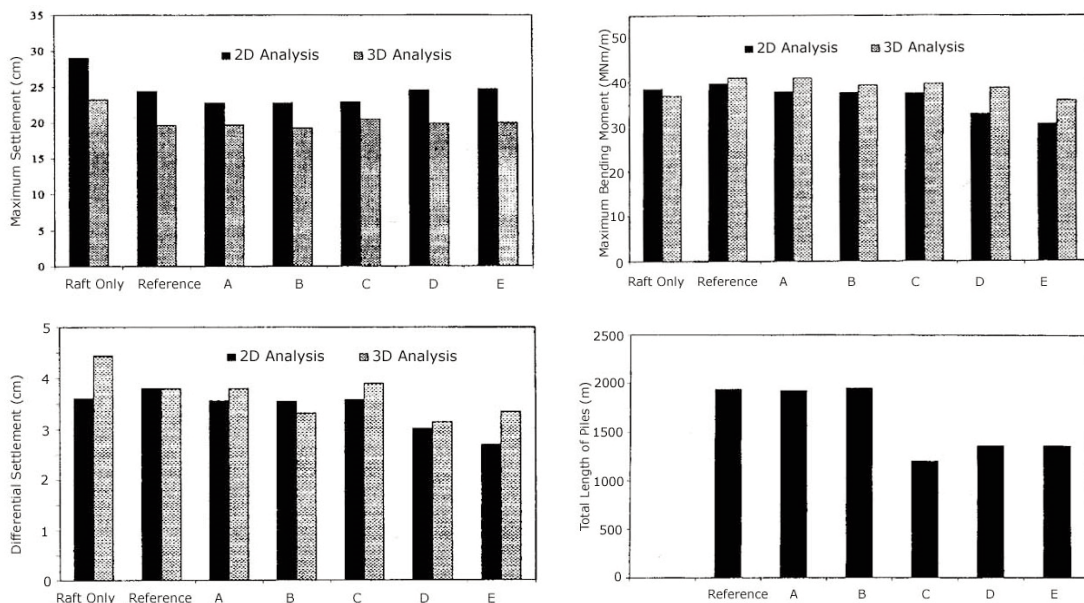

Fig. 12. Comparison of analysis results of different systems used for Messeturm building in Frankfurt, Germany

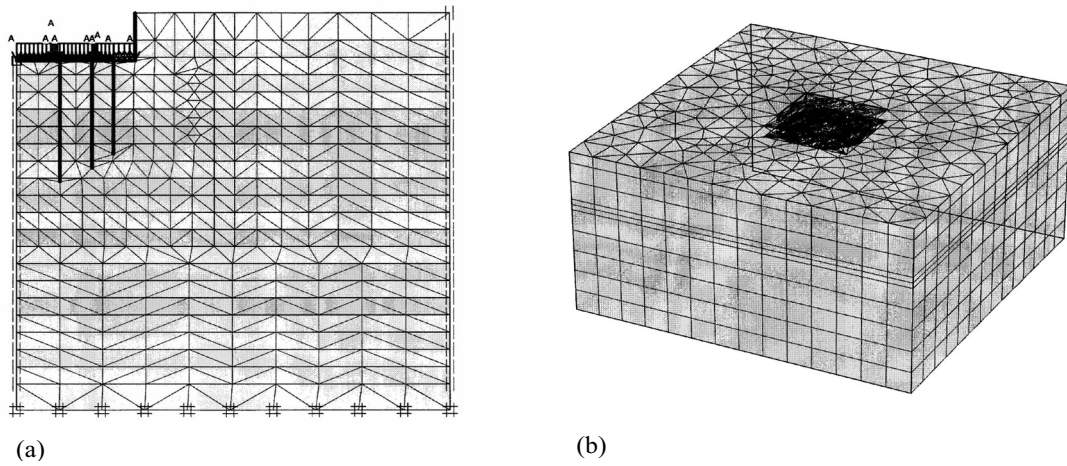

Fig. 12. FEM Modeling for messeturm building in Frankfurt, Germany a) 2-dimensional model and b) 3-dimensional model

Table 3. Mechanical properties of elements in 2D-FE analysis for messeturm building in reference analysis, Frankfurt, Germany (axisymmetric)

Mechanical Properties	Raft	Piles in Row A	Piles in Row B	Piles in Row C
EA (kN/m)	150000000	7041000	5030000	5092000
EI (kNm ² /m)	312500000	991600	708300	717100

reduction of the total number of piles beneath the foundation there would be a little or no change in the maximum settlements (cases C, D and E, Figure 12).

- For a constant raft thickness, the arrangement and length of piles have been recognized as the main factor in the settlement and internal moment reduction. For instance, the total length of piles is reduced from 1936m in the original (reference) case to 1360m in case E, but the differential settlement and internal moments are decreased significantly. Thus, the total number of piles in pile-group is not always the main factor in the settlement and the maximum internal moment reduction, but the major role is their location and concentration in the middle zone of the raft to compensate the dishing effect.

- The study indicates that the use of axi-symmetric elements not only leads to achievement of acceptable results, but this procedure can also reduce the computation time by a significant amount in comparison with the 3D analysis.

5. Conclusions

In recent development of piled-raft design, the raft has adequate bearing capacity and consequently, the main objective of introducing the pile elements is to control or minimize the average and/or differential displacements of the piled raft system, rather than to carry the major portion of the loads. Therefore, one alternative method of a combined foundation design is to introduce piles purely as a means of improving or enhancing the stiffness of the underlying soil by making use of piles which are not in contact with the raft. Based on the finite element analyses and implementing three building case histories with emphasis on optimized piled-raft design, the followings have been concluded:

- In a static loading state, concentration of piles in the middle region of the raft results in a significant reduction of differential settlement and maximum internal moments.

- Non-connected piles show to tolerate lower loads than connected piles under similar loading pattern. There is no other significant difference between connected and non-connected piles, except in case of piled-raft system tolerated horizontal or shear forces. This is a disadvantage that can be compensated by making use of base adhesion, shear keys and embedment depth.

- The results of the analyses in comparison with the site measurements accentuate that a two-dimensional modeling of foundations composed of non-connected piles and raft, with the aid of axisymmetric and plane strain elements, can satisfactorily be adopted instead of a time-consuming complex three-dimensional modeling, where a well-posed rectangular or circular arrangement of piles are employed. Also, a linear elastic model can be reasonably used for preliminary purposes, such as sizing, optimum pile arrangement and value engineering.

- Raft thickness has no significant effect on the average settlement and internal shear forces, but, has a great effect on the differential settlement and the maximum internal moment, i.e., the higher the thickness of the raft the higher the maximum internal moment but the lower the differential settlement. This case is subjective to the engineering judgment of the designer which includes the knowledge of geotechnical and structural aspects of the design.

- Increasing the pile length has a great effect on the reduction maximum settlement, but its effect on internal moments is negligible. It was also observed that the effect of the pile length on the differential settlement depends on the applied load intensity, i.e., in higher load intensities, application of the longer piles results in a decreasing tendency in the differential settlement.

- The function of piles configurations in raft geometry consequences a significant reduction of differential settlement, especially by concentrating the piles in the middle 15 to 25% of raft plan area.

- The effect of the total number of piles in piled raft is significant for higher load intensities.

References

- [1] Prakoso, W. A., Kulhawy, F. H. (2001). "Contribution to piled raft foundation design." *J. Geotech. Engng, ASCE*, 127(1), 17-24.
- [2] Eslami, A., Veiskarami, M. and Eslami, M. M. (2008). "Piled-Raft Foundation (PRF) Optimization Design with Connected and Disconnected Piles", Proceedings of the 33rd Annual and 11th Int'l Conference on Deep Foundations, October 15-17 2008, Deep Foundations Institute (DFI), New York, NY, U.S.A., pp. 201-211.
- [3] Veiskarami, M., Eslami, A., Ranjbar, M. M. and Riyazi, T. (2007). "Geotechnical Interaction of Mat Foundation and Pile Group, Two Case Studies", *Esteghlal Journal of Engineering*, Isfahan University of Technology, September, 2007, Vol. 36, No. 1, pp. 93-107.
- [4] Seo, Y. K., Lee, H. J., Kim, T. H. (2006). "Numerical Analysis of Piled-Raft Foundation Considering Sand Cushion Effects", Proceedings of the 16th International Offshore and Polar Engineering Conference, San Francisco, California, USA, May 28-June 2, 2006, pp. 608-613.
- [5] Reul, O., Randolph, M. F. (2004). "Design strategies for piled rafts subjected to nonuniform vertical loading." *J. of Geotechnical and Geoenvironmental Engineering, ASCE*, 130 (1), pp.1-13.
- [6] Randolph, M. F. (1994). "Design methods for pile groups and piled rafts." *State-of-the-Art Report*, 13th Int. Conf. Soil Mech. Foundn Engng, New Delhi, 5, 61-82.
- [7] Hassen, G and de Buhan, P. (2005). "Finite Element Elastoplastic of a Piled Raft Foundation Based on the Use of a Multiphase Model", Proceedings of the 8th International Conference on Computational Plasticity, COMPLAS VIII, Barcelona, Spain.
- [8] Wong, I. H., Chang, M. F. and Cao, X. D. (2004). "Behavior of model rafts resting on pile-reinforced sand." *J. Geotech. Engng, ASCE*, 130(2), 129-138.
- [9] Reul, O. and Randolph, M. F. (2003). "Piled Rafts in Overconsolidated Clay: Comparison of in situ Measurements and Numerical Analysis." *Géotechnique*, 53(3), 301-315.
- [10] Noh, E. Y., Huang, M., Surarak, C., Adamec, R. and Balasurbamaniam, A. S. (2008). "Finite Element Modeling for Piled-Raft in Sand", Proceedings of the Eleventh East Asia-Pacific Conference on Structural, Engineering & Construction (EASEC-11), "Building a Sustainable Environment", November 19-21, 2008, Taipei, Taiwan.
- [11] Moghaddas Tafreshi, S. N., (2008). "Uncouple Nonlinear Modeling of Seismic Soil-Pile-Superstructure Interaction in Soft Clay." *International Journal of Civil Engineering*, Iran University of Science and Technology Press, Vol. 6, No. 4, Dec. 2008.
- [12] Baziar, M. H., Ghorbani, A. and Katzenbach, R., (2009). "Small-Scale Model Test and Three-Dimensional Analysis of Pile-Raft Foundation on Medium-Dense Sand." *International Journal of Civil Engineering*, Iran University of Science and Technology Press, Vol. 7, No. 3, Sept. 2009.
- [13] PLAXIS 9 Scientific Manual (2008), Delft University of Technology & PLAXIS bv, the Netherlands, A. A. Balkema PUBLISHERS (<http://www.plaxis.nl>)
- [14] Desai, C. S., Johnson, L. D., and Hargett, C. M. (1974). "Analysis of pile supported gravity lock." *J. Geotech. Engng, ASCE*, 100(9), 1009-1029.
- [15] Cooke, R. W. (1986). "Piled raft foundations on stiff clays: a contribution to design philosophy." *Geotechnique*, London, England, 36 (2), 169-203.
- [16] Hemsley, J. A. (2000). "Design applications of raft foundations", Thomas Telford Ltd, London.
- [17] Cao, X. D., Wong, M. F. and Chang, M. F. (2004). "Behavior of model rafts resting on pile-reinforced sand." *J. Geotech. Engng, ASCE*, 130(2), 129-138.
- [18] Poulos, H. G. (2000). "Practical design procedures for piled raft foundations", Design application of raft foundations, Edited by J. A. Hemsley, Thomas Telford Ltd, London, 393-425.
- [19] Afsoon Coastal tower, Geotechnical Report, No.1382, Shame Consulting engineers Co. Tehran, Iran.
- [20] Randolph, M. F. (1983). "Design of Piled Raft Foundations." *Proc. Int. Symp. Recent Developments in Laboratory and Filed Tests and Analysis of Geotechnical problems*, Bangkok, 525-537.
- [21] Horikoshi, K. and Randolph, M. F. (1998). "A contribution to optimum design of piled rafts." *Geotechnique*, London, England, 48(3), 301-317.
- [22] Franke, E. (2000). "Calculation methods for raft foundations in Germany." Design application of raft foundations, Edited by J. A. Hemsley, Thomas Telford Ltd, London, 283-322.

Appendix A - Details of the computational procedure

The static equilibrium in a continuum is as follows [13]:

$$\Gamma^T \sigma + p = 0 \quad (A1)$$

In this equation, σ is the stress matrix (obtained from stress tensor), p is the force vector and Γ^T is a derivative operator defined as follows:

$$\Gamma^T = \begin{bmatrix} \frac{\partial}{\partial x} & 0 & 0 & \frac{\partial}{\partial y} & 0 & \frac{\partial}{\partial z} \\ 0 & \frac{\partial}{\partial y} & 0 & \frac{\partial}{\partial x} & \frac{\partial}{\partial z} & 0 \\ 0 & 0 & \frac{\partial}{\partial z} & 0 & \frac{\partial}{\partial y} & \frac{\partial}{\partial x} \end{bmatrix} \quad (A2)$$

In this manner, the strain vector (obtained from strain tensor) can be calculated as follows:

$$\varepsilon = \Gamma u \quad (A3)$$

In this equation, ε is strain vector and u is displacement vector. Thus, the stress and strains can be related to each other:

$$\sigma = D\varepsilon \quad (A4)$$

Where, D is a constitutive relation matrix that relates the rate of stress to strain change. In the Finite Element Method, the equilibrium equations are numerically solved in a domain that is discretized into several finite elements. The displacements of any point in within an element are calculated based on the following equation:

$$u = Nv \quad (A5)$$

Where, v is the nodal displacement matrix, u is the displacement of a certain point within an element and N is the matrix of the interpolation functions, also known as shape functions. PLAXIS code uses different shape functions for different type elements. Since the strains can be related to the nodal displacements in the following formula:

$$\varepsilon = \Gamma Nv = B^*v \quad (A6)$$

In which, B^* is the strain interpolation matrix, and the stresses within an element can also be related to nodal forces, the relationship between nodal forces and nodal displacements can be described as follows:

$$f = Kv \quad (A7)$$

In the above equation, f is the nodal force vector and K is known as the stiffness matrix defined as follows:

$$K = \int_{vol} B^{*T} DB^* dvol \quad (A8)$$

In PLAXIS code, the previous equations are solved in an iterative manner. According to the Finite Element Method, the

continuum is divided into a number of elements with a number of degree of freedom at each node. Then, for any increment of applied load, the displacement increment is calculated and nodal forces and displacements are obtained. This iterative procedure in PLAXIS code is defined as follows:

$$f^i - f^{i-1} = K(u^i - u^{i-1}) \quad (A9)$$

In this equation, f^{i-1} and f^i are forces at two successive steps; $i-1$ and i , and u^{i-1} and u^i are corresponding displacements at those steps of loading. Complete description of the PLAXIS code method of analysis for soil and rock environments is presented in PLAXIS Scientific manual [13].